

MAGNAMED



Operation Manual

OxyMag – Transport and Emergency Ventilator

This instructions for use applies to Oxymag – Transport and Emergency Ventilator - 1600185-10:
OxyMag, developed and manufactured by Magnamed Tecnologia Médica S/A.

Review of this instructions for use: nº 05
Software version: 3.n

All rights reserved by

Magnamed Tecnologia Médica S/A 
Rua Santa Mônica 801/831 – Capuava
CEP: 0671-865 – Cotia – SP – Brazil
Phone/Fax: +55 (11) 4615-8500
E-mail: magnamed@magnamed.com.br
Website: www.magnamed.com.br
CNPJ: 01.298.443/0002-54
State Registration: 149.579.528.111

Analytical Index

A.	DEFINITIONS	5	5.4	PROCEDURE TO RESET THE SENSOR	44
B.	WARNING	5	5.5	INFORMATION REGARDING LED	44
C.	CAUTION	7	5.6	PREVENTIVE MAINTENANCE OF EtCO ₂ SENSOR	45
D.	NOTES	7	5.7	TECHNICAL SPECIFICATIONS OF THE	
1.	DESCRIPTION	8	CAPNOGRAPHY.....		46
1.1	INTENDED USE	8	6	OXIMETER (MASIMO)	51
1.2	OPTIONAL ITEMS COMPATIBLE WITH THE		6.1	OPERATION PRINCIPLE	51
PRODUCTS	9		6.2	SUMMARY OF BLOOD CALIBRATION TEST	55
2.	UNPACKING THE PRODUCT	10	6.3	LOW PERFUSION TEST SUMMARY	55
2.1	INITIAL CHECKS	10	6.4	SENSOR ASSEMBLY	55
2.2	PARTS AND ACCESSORIES	11	6.5	OXIMETER SPECIFICATION	56
2.3	OPTIONAL ACCESSORIES THAT CAN BE PURCHASED		7	DESCRIPTION OF MODES.....	58
FOR OXYMAG.....	11		7.1	VCV – VOLUME CONTROLLED VENTILATION....	58
2.4	COMPONENTS OF TRANSPORT VENTILATOR	16	7.2	PCV – PRESSURE CONTROLLED VENTILATION ..	60
2.4.1	PROTOCOL USED FOR DATA COMMUNICATION WITH		7.3	PLV –LIMITED PRESSURE VENTILATION	62
EXTERNAL DEVICES.....	18		7.4	V-SIMV – SYNCHRONIZED INTERMITTENT	
3.	DESCRIPTION OF THE DISPLAY	21	MANDATORY VENTILATION – VOLUME CONTROLLED CYCLE.		64
3.1	HOME SCREEN	21	7.5	P-SIMV – SYNCHRONIZED INTERMITTENT	
3.2	MAIN SCREEN.....	21	MANDATORY VENTILATION – PRESSURE CONTROLLED CYCLE		66
3.2.1	MODES	22	7.6	CPAP/PSV – CONTINUOUS PRESSURE	
3.2.2	MUTE	22	VENTILATION WITH PRESSURE SUPPORT		68
3.2.3	MONITOR	22	7.7	DUALPAP – BI-LEVEL CONTINUOUS POSITIVE	
3.2.4	STANDBY	22	AIRWAY PRESSURE VENTILATION		70
3.2.5	LOCK.....	22	7.8	APRV –AIRWAY PRESSURE RELEASE VENTILATION	
3.2.6	ALARMS AND MESSAGES	22	(MODE OBTAINED WITH INVERTED RATIO IN DUALPAP)		72
3.2.7	BATTERY STATUS.....	22	7.9	CPR – CARDIOPULMONARY RESUSCITATION....	74
3.2.8	BAR GRAPH	22	7.10	HFOT – HIGH FLOW OXYGEN THERAPY	75
3.2.9	SET PARAMETERS	23	8	ALARMS AVAILABLE	78
3.2.10	GRAPHIC AREA	23	8.1	DESCRIPTION OF ALARM CONTROL	78
3.2.10.1	ALARM MENU.....	23	8.2	SETTING ALARMS	88
3.2.10.2	CONFIG MENU	24	8.3	ALARM TEST	88
4.	PREPARATION FOR USE.....	26	8.3.1	ADJUSTABLE ALARM TEST	88
4.1	ASSEMBLING OXYMAG – TRANSPORT VENTILATION		8.3.1.1	PRESSURE ALARM	88
	26		8.3.1.2	PEEP ALARM	88
4.2	NONINVASIVE VENTILATION MASK	28	8.3.1.3	MINUTE VOLUME ALARM (MV)	89
4.3	POWER CONNECTION	29	8.3.1.4	RESPIRATORY RATE ALARM.....	89
4.4	ASSEMBLING THE SUPPORTS.....	30	8.3.1.5	VOLUME ALARM.....	89
4.4.1	ASSEMBLING THE VERTICAL SUPPORT	30	8.3.1.6	FI _{O2} ALARM	89
4.4.2	ASSEMBLING THE SUPPORT FOR AIR TRANSPORT		8.3.1.7	EtCO ₂ ALARM.....	89
	31		8.3.1.8	PULSE RATE ALARM	89
4.5	CHECKS BEFORE USE	33	8.3.1.9	CO ₂ ALARM	89
4.6	INITIAL PROCEDURES.....	33	8.3.1.10	SPO ₂ ALARM	90
4.7	VENTILATOR SETTINGS	34	8.3.1.11	APNEA ALARM	90
4.7.1	NORMAL STARTUP SEQUENCE.....	36	8.3.2	CRITICAL ALARM TEST	90
4.7.2	TEST SEQUENCE	38	8.3.2.1	DISCONNECTION.....	90
4.7.3	FAILURE DIAGNOSIS	39	8.3.2.2	NO AC POWER.....	90
5	CAPNOGRAPHY SENSOR (ETCO₂).....	41	8.3.2.3	LOW BATTERY	90
5.1	INSTRUCTIONS FOR USE.....	41	8.3.2.4	OBSTRUCTION	90
5.2	ASSEMBLING THE SENSOR.....	41	8.3.2.5	LOW O ₂ SUPPLY.....	90
5.3	POSITIONING THE SENSOR.....	43	8.4	MANUAL VENTILATION OF THE PATIENT.....	90
			9	CLEANING AND DISINFECTION	92

9.1	EQUIPMENT CLEANING	92	13.3.4	INTERNAL VOLUME OF RESPIRATORY CIRCUIT	
9.1.1	EXTERNAL VENTILATOR SURFACES	92	COMPONENTS.....		106
10.1.2	AUTOCLAVABLE RESPIRATORY CIRCUIT, PROXIMAL		13.3.5	EXTREME CONDITIONS.....	106
	FLOW SENSOR AND EXHALATION VALVE	92	13.3.6	VENTILATION MODES.....	107
9.1.1.1	WASH.....	92	13.3.7	SETTING SPECIFICATIONS OF THE VENTILATION	
9.1.1.2	RINSE.....	92	PARAMETERS		108
9.1.1.3	DRYING	93	13.3.8	SPECIFICATIONS OF THE MONITORING	
9.2	DISINFECTION.....	93	VENTILATION PARAMETERS		111
9.2.1	EXTERNAL PARTS	93	13.3.9	CONTROL ACCURACY	114
9.2.2	AUTOCLAVABLE RESPIRATORY CIRCUIT,		13.3.10	SPECIFICATIONS OF THE SAFETY AND	
	EXHALATION VALVE, PROXIMAL FLOW SENSOR AND SILICONE		ALARM SYSTEM		114
LINE	93		13.3.11	CONCENTRATION X PRESSURE IN THE	
9.3	STERILIZATION	93	BREATHING CIRCUIT CURVE		118
9.4	PROCESSING METHODS	94	13.3.12	PERFORMANCE SPECIFICATIONS.....	118
10	PREVENTIVE MAINTENANCE	95	13.3.13	SPECIFICATIONS FOR MAINTENANCE AND	
10.1	INDICATION OF THE NEED FOR PERIODIC		CALIBRATION		119
	MAINTENANCE.....	95	13.3.14	MASK FOR NON-INVASIVE VENTILATION	120
10.2	DAILY CHECKS AND/OR PRIOR TO USE	95	13.3.15	BREATHING CIRCUIT	120
10.3	INTERNAL LITHIUM BATTERY.....	95	13.3.16	HME FILTER.....	120
10.4	INTERNAL SENSOR OF O ₂ CONCENTRATION.....	96	13.3.17	SPECIFICATIONS FOR RESISTANCE OF THE	
10.5	REPLACING THE AMBIENT AIR FILTER.....	97	EXPIRATORY LIMB		121
10.6	FORWARDING THE PRODUCT TO REPAIR SERVICE		13.3.18	PNEUMATIC DIAGRAM.....	122
	97		13.3.19	BLOCK DIAGRAM OF CONTROL	
11	DISPOSAL	99	ELECTRONICS		123
12	TURNING OFF THE EQUIPMENT	100	13.3.20	ELECTROMAGNETIC COMPATIBILITY	124
13	TECHNICAL SPECIFICATION.....	101	13.4	O ₂ GALVANIC CELL SPECIFICATION	130
13.1	CLASSIFICATION	101	14	SYMBOLS.....	131
13.2	STANDARDS.....	101	15	TERMS AND ABBREVIATIONS.....	136
13.3	SPECIFICATIONS	102	16	STATEMENT OF BIOCOMPATIBILITY	138
13.3.1	ELECTRICAL CHARACTERISTICS	103	17	WARRANTY	139
13.3.2	CONNECTING TO THE OXYGEN SUPPLY	104	18	TECHNICAL ASSISTANCE.....	140
13.3.3	PHYSICAL AND ENVIRONMENTAL SPECIFICATIONS		19	TRAINING	141
	105				

Safety Notes

a. Definitions

WARNING

- *It is to inform the user of the possibility of injury, death or other serious adverse reaction associated with the use or misuse of the equipment.*

Caution

- It is to inform the user of the chance to occur failure in the equipment associated with the use or misuse, such as equipment malfunction, equipment damage, or damage to third's property, and indirectly, injury to a patient.

Note

- Important information.

b. Warning

WARNING

- Where there is the symbol  read the instruction manual for more details, this manual should be read in its entirety, CAREFULLY, for correct and safe use of the equipment and to provide maximum safety and best resources to patients. Check all Warnings and Cautions in this manual and on the labeling of the equipment.
- This equipment should be operated only for the purpose specified in 1.1 Intended Use in conjunction with appropriate monitoring.
- This equipment must be operated only by a qualified professional in the health care area with expertise in mechanical ventilation qualified and trained in its use, who should monitor closely during its use. Including ventilation limited to volume.
- This equipment and the parts should go through a cleaning process each time it is used, including the first use, as indicated in chapter 10 Cleaning and Disinfection.
- This equipment shall pass the "Basic adjustments and checking procedures" to ensure the effectiveness of the equipment and the safety of the operator and patient, as indicated in chapter 5 Checks Before Use.
- This equipment must remain ALWAYS be connected to a power grid so that there is enough charge during a power outage.

- *This equipment must issue three beeps when started, demonstrating the correct operation of audible signal.*
- *This equipment, parts and accessories must be disposed according to chapter 12 Disposal;*
- *This equipment must be switched off with the patient disconnected on the on/off switch.*
- *This equipment should not be used with transmission devices in the vicinity of the transport ventilator, such as mobile phones, point-to-point radio transmission, cordless phones, pagers, high-frequency surgical equipment, defibrillators, short-wave therapies, which could stop operation of the ventilator.*
- *This equipment should not be used during a magnetic resonance imaging (MRI, NMR, NMI), because this could cause interference, and can cause adverse effects to the patient.*
- *This equipment should not be used in areas containing harmful substances, because it aspirates ambient air to ventilate the patient, once set at less than 100% O₂ concentrations.*
- *This equipment should not be used with flammable anesthetic agents because there is risk of explosion.*
- *The ventilator shall not be used in a hyperbaric chamber. Such use might cause the ventilator to not function correctly causing patient death or additional serious deterioration of health.*
- *After prolonged use of the equipment in environments with particulate matter in suspension, replace the filter as indicated in chapter 11.5 Replacing the Ambient Air Filter.*
- *Parts applied to transport ventilator support defibrillation.*
- *Alarms and Alerts should be treated promptly in order to maintain the operation integrity of the equipment and patient safety, as indicated in chapter 9 Alarms Available.*
- *Do not use hoses or antistatic or electrically conductive tubes.*
- *After starting ventilation, check if the ventilation parameters indicated by the monitoring display are appropriate.*
- *Use only parts, pieces and accessories specified by MAGNAMED listed in this manual, which have been tested and approved for use in conjunction with this equipment; otherwise, it can jeopardize the operation endangering the patient or user.*
- *It is essential for ventilation monitoring that the flow sensor is correctly connected and unblocked; therefore, this sensor must be frequently checked during operation.*
- *When turning on the ventilator, please inform the patient type and this will set the proper ventilation. Connect the flow sensor with the type of patient informed so that ventilation is properly monitored.*
- *Oxymag and all parts applied to are made of non-toxic material, latex-free, do not cause irritation or allergy to the patient. Applied parts are: patient breathing circuit, flow sensor and silicone line, exhalation valve, oximetry and capnography sensor.*
- *Use MASKS specified by MAGNAMED with local registration;*
- *Use MASK suitable for patient type.*
- *Always use oxygen cylinders officially approved and pressure*

reducing valves that meet local government requirements.

- *Consider the dead space of the breathing circuit to make adjustment in the ventilator, especially for small tidal volumes.*
- *Test Sequence must be performed with the patient disconnected.*
- *Do not expose the product to extreme temperatures beyond the specified in item 14.3.3 Physical and Environmental Specifications during its use. The equipment performance*

may be adversely affected if the operating temperature is beyond the specified limits.

- *HME filter, HEPA filter and airway adapter are single use. The reuse of these accessories may cause cross contamination.*
- *During prolonged use of the equipment in patients with excess secretion, the condition of the flow sensor shall be checked frequently, seeking to drain accumulated fluid into the breathing circuit as needed.*

c. Caution

Caution

- Oxymag does not emit electromagnetic waves that interfere with the equipment operation in the vicinity.
- Oxymag must pass annual periodic maintenance or according to the hours of use as specified, whichever comes first.
- Oxymag must have the ambient air intake filter replaced every 500 hours of use, or at shorter intervals, if the environment in which it is used contains too much particulate matter in suspension.
- Oxymag should have its maintenance performed only by a qualified, trained technician duly authorized by MAGNAMED.

d. Notes

Note

- There are additional contraindications, in addition to those specified in Warning items in page 5 of this manual. It remains the responsibility of the trained operator the choice and selection of suitable respiratory mode to each patient.
- The technical characteristics of MAGNAMED Products are subject to change without notice
- All ventilator parts, pieces and accessories that are subject to disposal must comply with the recommendations of Chapter 12 Disposal.
- Pressure units:

1 mbar (millibar) = 1 hPa (hectoPascal) = 1.016 cmH₂O (centimeter of water)

In practice, these units are not differentiated and can be used as:

$$1 \text{ mbar} = 1 \text{ hPa} \approx 1 \text{ cmH}_2\text{O}$$

1. Description

1.1 Intended Use

Oxymag MAGNAMED's Transport and Emergency Electronic Ventilator – belong to the family of equipment for ventilatory support of neonatal, pediatric, and adult patients with respiratory failure, with controlled volume, pressure and time cycled. Intended for use in patients from neonatal, pediatric, adult and adults with morbid obesity. Oxymag interacts with the patient through an invasive or noninvasive interface that supplies ventilator air to the patient's airway.

Oxymag provides a mixture of ambient air and oxygen at concentrations adjusted by the operator using the accurate oxygen concentration System using the venturi principle. O₂ concentration is obtained through a galvanic cell by indirect contact with the patient's gas by passing gas through the sensor. In addition, it performs the control of flows and pressures in the respiratory circuit to provide the ventilation modalities appropriate to the patient's condition.

The possible ventilation modes of this ventilator are:

- VCV – Volume Controlled Ventilation (can be Assisted);
- PCV – Pressure Controlled Ventilation (can be Assisted);

During ventilation in CPAP/PSV a backup ventilation can be established in the case of APNEA; this ventilation can be chosen between VCV, PCV, PLV or OFF.

- PLV – Pressure Limited Ventilation (can be Assisted) – Available Weight ≤ 6.0Kg (Neonatal).
- P-SIMV – Synchronized Intermittent Mandatory Ventilation with Pressure Controlled cycle.
- V-SIMV – Synchronized Intermittent Mandatory Ventilation with Volume Controlled cycle.
- CPAP/PSV – Continuous Pressure Ventilation with Pressure Support.
- DualPAP – Ventilation at two CPAP levels (with or without Support Pressure). Adjustments can be performed through this modality in order to obtain APRV mode (Airway Pressure Release Ventilation);
- Noninvasive ventilation (NIV) by mask can be activated in all ventilation modes with leakage compensation (except CPR and HFOT).
- CPR – Cardiopulmonary Resuscitation (optional).
- HFOT – High Flow Oxygen Therapy (optional).

WARNING

- ***This device should be operated only by healthcare professional with expertise in mechanical ventilation and qualified and trained in its use.***
- ***In CPAP/PSV and DUALPAP modes ΔPS = OFF should be set to deactivate the***

support pressure and BACKUP should be set to OFF to deactivate backup ventilation. Be aware that when adjusting parameter BACKUP to OFF backup ventilation will be INACTIVE during APNEA.

Pulmonary ventilation may be performed in the following conditions:

- In emergency medicine for service in the field, primary care, rescue in which the patient can be transported by land or air, including fixed wing aircraft helicopters.
- Postoperatively, in the post-anesthetic care unit (PACU);
- Intra-hospital transportation: The patient can be transported internally, from one to another department.
- Inter-hospital transportation: The patient can be transported by road.

1.2 Optional items compatible with the products

This equipment is compatible with the following items:







- Nasal prong for neonatal CPAP and its breathing circuit, both must comply local legal government requirements.
- Breathing circuits with trachea, which resistance is less than 0.3 mbar/(L.s⁻¹) that comply local legal government requirements;
- Blender with flow 120ml/min and outlet pressure 60psi that complies local legal government requirements.
- Adult, Pediatric and Neonatal Simple Facial Masks that comply local legal government requirements.
- HME filter that complies local legal government requirements (to be used in accordance with the patient being ventilated).
- Aluminum cylinder for oxygen M9 for carrying case, that complies local legal government requirements, namely:
 - Diameter = 11.13 cm;
 - Height = 27.20 cm;
 - Volume = 1.7L;
 - O₂ Capacity = 255L.

2. Unpacking the Product

2.1 Initial Checks

- ✓ Make sure the packaging is intact checking for dents, holes or other damage.
- ✓ If the package is found damaged, please report immediately the Responsible carrier and MAGNAMED and DO NOT open the package.
- ✓ Open the package carefully observing the signs in the box.
- ✓ Check the content in accordance with the following list of components.

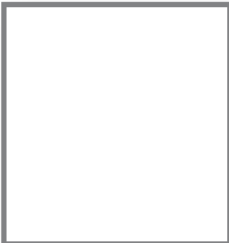
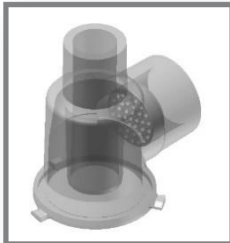
Table 1: List of components for OxyMag

List of components for OxyMag	
	<p>OXYMAG TRANSPORT AND EMERGENCY VENTILATOR</p> <p>Part Number 1600185 Quantity: 1 unit</p>
	<p>POWER OUTLET 12V/3,34A MEDICAL DEGREE</p> <p>Part Number 2402568 Quantity: 1 unit</p>
	<p>AC CABLE 3 WAYS 1,5 M</p> <p>Part Number 2802612 Quantity: 1 unit</p>
	<p>ADULT BREATHING CIRCUIT ¹ 1,2m AUTOCLAVABLE</p> <p>Part Number 1703218 Quantity: 1 unit</p>
	<p>QUICK GUIDE OXYMAG FAMILY</p> <p>Part Number 7006467 Quantity: 1 unit</p>
	<p>EXHALATION VALVE WITH STABILIZING RING</p> <p>Part Number 3804865 Quantity: 1 unit</p>
	<p>DIAPHRAGM OF EXHALATION VALVE MAGNAMED</p> <p>Part Number 3800248 Quantity: 1 unit</p>
	<p>ENVELOPE WITH 3 ENVIRONMENT FILTERS</p> <p>Part Number 1702656 Quantity: 1 unit</p>



**KIT FLOW SENSORS
ADU PED NEO AUTOCLAVABLE**
01 Silicon line, 03 Flow sensors (1 Adult; 1 Pediatric, 1 Neonatal)
Part Number 5001748
Quantity: 1 unit



USER MANUAL
Part Number 1600185-NE-171-RR
Quantity: 1 unit

2.2 Parts and Accessories

Caution

- Always use original parts and accessories to ensure the safety and effectiveness of the equipment.
- Parts and pieces indicated in this instruction for use may be used in the patient environment.

2.3 Optional accessories that can be purchased for Oxymag

Table 2: List of optional components for Oxymag.

List of optional accessories for Oxymag



**STAND WITH CASTERS FOR
OXYMAG**
Part Number 3802668



**ARTICULATED ARM WITH
SUPPORT FOR BREATHING
CIRCUITS**
Part Number 1708046



**PEDIATRIC AND NEONATAL
BREATHING CIRCUIT 1.2M
AUTOCLAVABLE**

Part Number 1702654



**VERTICAL SUPPORT FOR
AMBULANCE OR HELICOPTER
WITH SAFETY LATCH**

Part Number 1702496

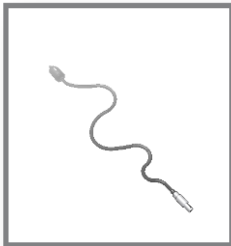

**POWER CORD DC 12V 4-WAY
WITH CAR PLUG**

Part Number 2802671



**CARRYING BAG FOR OXYMAG
WITHOUT CYLINDER**

Part Number 1704784



CARRYING BAG FOR OXYMAG

Part Number 1702875



**KIT PEDIATRIC FLOW
SENSORS AUTOCLAVABLE**

- 01 Silicone Line
- 03 Pediatric Flow Sensors Autoclavable:

Part Number 5001746



**KIT ADULT FLOW SENSORS
AUTOCLAVABLE**

- 01 Silicone Line
- 03 Adult Flow Sensors Autoclavable

Part Number 5001747



**KIT ADULT FLOW SENSORS
AUTOCLAVABLE**

- 05 Silicone Lines
- 05 Adult Flow Sensors Autoclavable

Part Number 5001495



KIT NEONATAL FLOW SENSORS AUTOCLAVABLE

- 01 Silicone Line
- 03 Neonatal Flow Sensors Autoclavable

Part Number 5001745



KIT NEONATAL FLOW SENSORS AUTOCLAVABLE

- 05 Silicone Line
- 05 Neonatal Flow Sensors Autoclavable

Part Number 5001493



KIT PEDIATRIC FLOW SENSORS AUTOCLAVABLE

- 05 Silicone Line
- 05 Pediatric Flow Sensors Autoclavable

Part Number 5001494



IRMA CO2 GAS ANALYZER (EtCO2)

Part Number 1704388



AIRWAY SENSOR IRMA CO2 WITH 5-WAY CONNECTOR

Part Number 1704396



IRMA AIRWAY ADAPTER, ADULT/PEDIATRIC

Part Number 1704395



IRMA AIRWAY ADAPTER, INFANT

Part Number 1704394



SPO2 – NEO AND PED PULSE OXIMETER SENSOR AND CABLE ADAPTER (LNCS YI multisite SpO2 reusable sensor)

Part Number 1704410



SPO2 – ADULT PEDIATRIC PULSE OXIMETER SENSOR AND CABLE ADAPTER (LNCS DC-I SpO2 Adult Reusable Finger Clip Sensor

Part Number 1704409



KIT DISPOSABLE BREATHING CIRCUIT ADU – OXYMAG
Part Number: 1708936
Quantity: 1 unit

Content:
01 Disposable breathing circuit 22 mm x 1,5 m (CE: 1984)
01 Adult flow sensor
01 Exhalation valve 22 mm
01 Diaphragm
01 Silicone line 1,6 m



KIT DISPOSABLE BREATHING CIRCUIT PED – OXYMAG
Part Number: 1708937
Quantity: 1 unit

Content:
01 Disposable breathing circuit 22 mm x 1,5 m (CE: 1984)
01 Pediatric flow sensor
01 Exhalation valve 22 mm
01 Diaphragm
01 Silicone line 1,6 m



KIT DISPOSABLE BREATHING CIRCUIT NEO – OXYMAG
Part Number: 1708946
Quantity: 1 unit

01 Disposable breathing circuit 22 mm x 1,5 m (CE: 1984)
01 Neonatal flow sensor
01 Exhalation valve 22 mm
01 Diaphragm
01 Silicone line 1,6 m

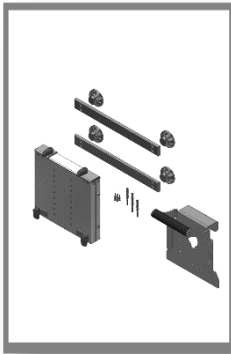

OXYMAG AIRCRAFT SUPPORT¹

- 1 Aircraft Support Kit (1710071)
- 1 Rail Kit (1710121)²

Part Number: 1710130

1 Accessories not available for the European Union

2 According to ISO 19054

2.4 Components of transport ventilator

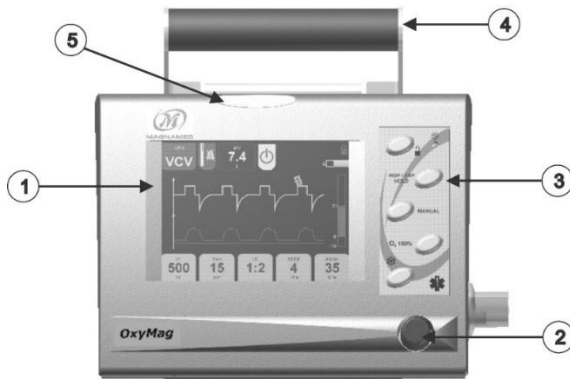

Figure 1: Frontal Panel of transport ventilator.

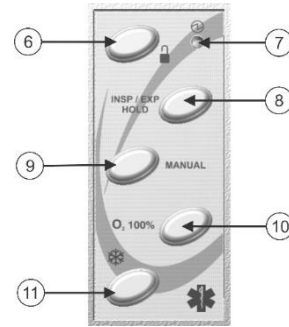

Figure 2: Side Keyboard

Table 3: Description of the frontal panel and the side keyboard components of the transport ventilator

Components of Figures 1 and 2	
1. LIQUID CRYSTAL DISPLAY WITH TOUCH SCREEN	Visual and graphical presentation of the setting parameters with touch screen.
2. KNOB BUTTON	<p>This button is used for most of the adjustments to be made in the Transport Ventilator OxyMag.</p> <ul style="list-style-type: none"> Select the parameters to be set on the display by directly touching the corresponding button. The selected button will change color to YELLOW allowing the change of values or adjustments. Set the desired value by turning the knob clockwise or counterclockwise. To confirm press the button <p>When the button returns to its original color the parameter set will be in effect.</p>
3. KEYBOARD	The keypad buttons allow quick access to the ventilator functions.
4. HANDLE	This handle allows to carry the ventilator during rescue and emergency operations. At the rear of the ventilator, there is a support that can be easily adapted to the patient stretcher.
5. ALARM INDICATOR LIGHT – RED	The alarm indicator light flashes when an alarm condition of high priority occurs. When in silent mode, it remains activated indicating the alarm condition.
6. LOCK TOUCH SCREEN	This key allows to lock or unlock the touch screen. When the commands on the display are locked, press this key for 2 seconds to release them. To lock again simply press this key once or wait 60 seconds without touching the screen.
7. GREEN LED – CONNECTION TO MAINS	The GREEN LED will be lit when the DC power inlet or power supply 12VDC inlet are connected

Components of Figures 1 and 2

8. HOLD KEY (PAUSE)

This key allows to suspend inspiration maneuvers, often used in cases of chest X-ray and maneuvers to extend the time of expiration (extend the expiration time).

If pressed during the inspiratory time of the respiratory cycle, the inspiration will be prolonged for 5 seconds; after this period, parameter Cest will be displayed in the monitoring area at the top center of the screen. If this key is pressed during the exhalation time, expiration will be extended for 5 seconds; after this period, the parameter PEEPi will be displayed in the monitoring area in the top center of the screen.

The parameters displayed after actuating this key will be visible for 5 seconds; after this period, the monitoring upper are will again display the parameter previously displayed.

9. MANUAL KEY

This key trigger an inspiratory cycle of support pressure. And is active in the VCV, PCV, V-SIMV, CPAP/PSV, P-SIMV, DUALPAP, PLV, CPR modes. In CPR mode, pressing this key performs a PSV cycle in the compression intervals.

10. O2 100% KEY

By pressing key to "O2 100%" the oxygen concentration will remain at 100% during the next 90 seconds. This ventilator may be used with closed suctioning. This feature can be used for pre-aspiration and post-aspiration procedures of secretions from the airways. When the ventilator is in STAND-BY, after pressing this button for 2 seconds, an oxygen flow meter will be displayed in the ventilator screen. At the top of the screen, the set value of the flow meter is displayed and at the bottom the value measured of the flow delivered is displayed. Use the button "Set and Confirm" to change the value of the desired flow.

11. FREEZE KEY

Freezes the graph layout to allow the analysis of the curves.

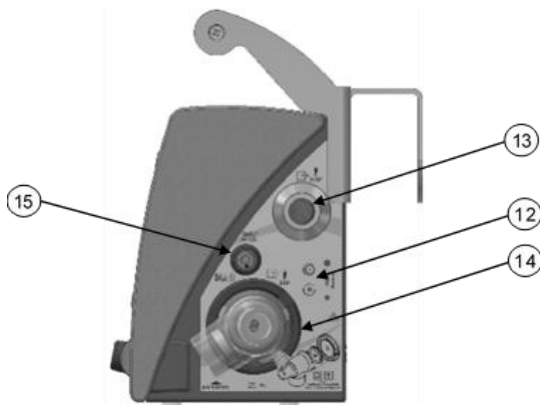

Figure 3: Right side view

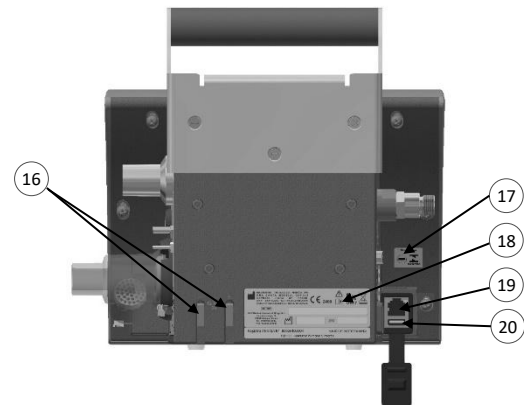

Figure 4: Back view

Table 4: Description of components of the right and the back side of the transport ventilator.

Description of the items in Figure 3 and 4	
<p>12. FLOW SENSOR CONNECTIONS These connectors are used to connect the flow sensor.</p>	<p>15. CONNECTOR TO THE CO2 SENSOR or SpO2 SENSOR Connection to the CO2 sensor of PHASE IN or MASIMO SpO2 sensor (these sensors are optional)</p>
<p>13. CONNECTOR 22M/15F OF INSPIRATORY FLOW Standard connection of the inspiratory flow to the breathing circuit of the patient</p>	<p>16. PLUG OF POWER SUPPLY – BASE This plug is used together with the support base of OxyMag and the power supply system. The inlet is +12VDC. Note the polarity indication and the recorded voltage DC power.</p>
<p>14 EXHALATION VALVE Connection of the expiratory limb of the breathing circuit of the patient.</p>	<p>17. LABELING TAG This is the INMETRO seal of compliance and safety.</p>

Description of the items in Figure 3 and 4	
<p>18. LABELING TAG This labeling tag brings MAGNAMED information, European Authorized Representative, Registration number at ANVISA, month and year of manufacture and serial number.</p>	<p>19. ETHERNET RJ-45 CONNECTOR (optional) RJ-45 Ethernet Standard Connector Used to send data to an electronic health recorder and to share information on monitored parameters, waveforms, and alarms via a communication protocol (HL7). It is not possible to control the equipment remotely through this port.</p>
<p>20. USB CONNECTOR (optional) The USB port is for maintenance purposes only and should be accessed by trained and authorized MAGNAMED personnel only.</p>	

Caution

- Use an ANSI / TIA / EIA-568 or higher CAT 5E cable category with a maximum length of 3 meters to connect to the ventilator's network port.
- Use only certified cables on the equipment's connectors.
- Connecting the ventilator to an IT network may result in risks to the patient, operator, or others not previously identified. The responsible organization must identify, analyze, assess, and control these risks.
- Subsequent changes to the IT network may introduce new risks and require additional analysis by the responsible organization. Changes to the IT network include configuration changes, connection of additional items, disconnection of items, upgrading of equipment connected to the IT network, and enhancement of equipment connected to the data communication port.
- Failure to implement the communication protocol will result in failure to send data to other equipment.

2.4.1 Protocol used for data communication with external devices

The Ethernet port can be used to share ventilator data such as set parameters, monitored parameters, waveforms, and alarm logging to electronic health recorders. Data has an average delay of 8 seconds from the time of data generation to the data output connector.

To send data to electronic health recorders, the IT network must be scalable, with high availability and low data propagation delay.

Required network configurations include a Dynamic Host Configuration Protocol (DHCP) enabled network server so that SEMP receives a valid Internet Protocol (IP). Communication is performed through the TCP protocol in the IT network. For communication with the electronic health recorder, an appropriate communication protocol must be implemented. For the communication protocol implementation guide, contact Technical Assistance / Magnamed.

The information goes as follows: Oxymag sends the data to the answering electronic health recorder it has received. The electronic health recorder may ask questions or request data to Oxymag who immediately responds or confirms the request.

Caution

- For the communication protocol implementation guide, contact Technical Assistance / Magnamed.
- This implementation should be performed on a network with the characteristics described in 2.4.1 by an IT specialist.
- IT network failures to provide the required characteristics may lead to delays in data communication or incorrect, incomplete, or corrupted data transmission, resulting in incorrect information to the user.

WARNING

- **Only rely on the ventilator for alarm signal generation and information. The IT network is not reliable for receiving alarm signals. Therefore, do not use a distributed alarm system as the only means to recognize alarm signal generation.**

The parameters are monitored based on the pressure and the FiO2 measurements performed by oxygen monitor.

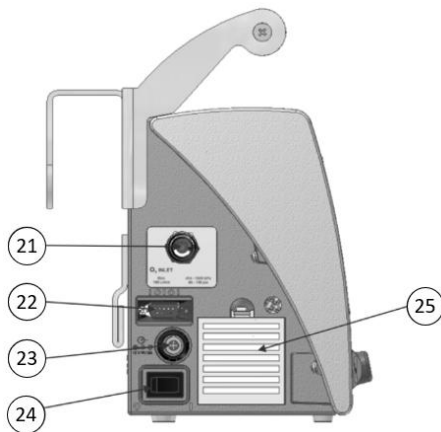

Figure 5: Left side view

Table 5: Description of the components found in the left side

Description of the items in Figure 5
<p>21. OXYGEN INLET Connect oxygen. Inlet pressure should be in the range of 39 to 87 psi (270 to 600 kPa). Standard DISS connection (ISO 5359).</p>
<p>22. SERIAL CONNECTION Serial Communication – RS-232 – female DB-9 connector for software update and data export to external devices.</p>
<p>23. INLET +12VDC – External AC/DC Source Power supply input +12VDC – Connection to external AC/DC source through the plug</p>
<p>24. On/Off Switch On/Off Switch</p>
<p>25. Air Inlet Filter Ambient air intake filter which is mixed with oxygen to provide oxygen concentrations less than 100%. Filter should be replaced according to the descriptive operations manual (12.Replacing the Ambient Air Filter).</p>

WARNING

- **Only use power supply, parts, pieces, and accessories specified by MAGNAMED listed in this manual, which were tested and approved for use in conjunction with this equipment; otherwise, this can jeopardize the operation endangering the patient or user.**

Caution

- If there is no confirmation by pressing the button, after 10 seconds the parameter value and the button will return to the previous state.
-

Note

- For electrical insulation of the ventilator circuits from the external source, only disconnect the power supply input+12VDC of the equipment.
-

3. Description of the Display

3.1 Home Screen

By starting the ventilator, the following screen will be displayed:

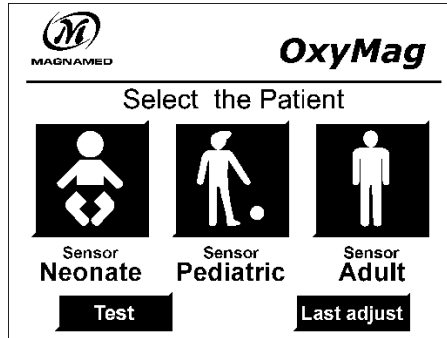

It is recommended to perform the autotest before starting the ventilation. To do this, press the button “Test” and follow the instructions on the screen. For more information, see chapter 4.7.2 - Test Sequence.

To start the ventilation, choose the patient and click on the corresponding button. For more information, see chapter 4.7 Ventilator Settings

To quickly start a ventilation with the same configuration of the previous ventilation, select the button “Last adjust”.

3.2 Main screen

By clicking on the patient in the previous step, the following screen will be displayed:

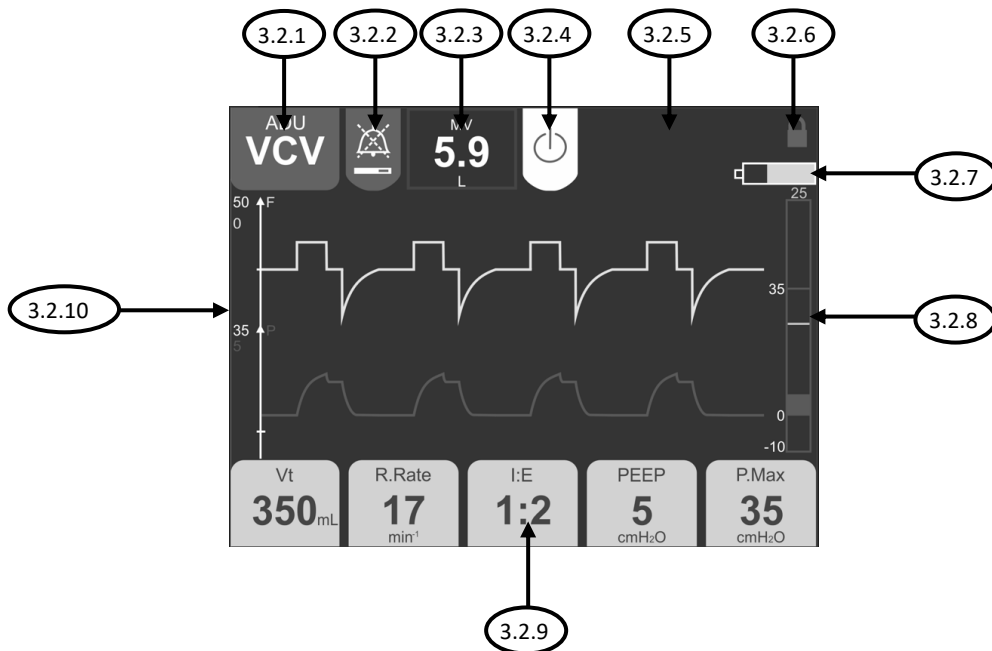

3.2.1 Modes

In the upper left corner, there is the indicator of:

- Type of patient selected: Adult; Pediatric, Neonatal;
- Active Mode;
- NIV indication, this will compensate for leaks

By clicking this button, all ventilatory modes available for the selected patient type will be displayed. To change the mode, click on the desired mode, and set the parameters that will blink in yellow.

3.2.2 Mute

By clicking on the mute button, the alarms will be muted for 2 minutes or until another alarm starts. When the alarm is muted, a bar indicating the mute time is shown.

3.2.3 Monitor

By clicking on this button, the following monitored parameters will be displayed: MV – Minute Volume Monitored, Vte – Volume Expired or PMax – Maximum Pressure. To change the parameter displayed, simply touch the screen on the parameter.

When performing the inspiratory or expiratory pause, in this area will be displayed the monitored Static Compliance (C.Stat) and the Intrinsic PEEP (PEEPi).

3.2.4 Standby

To put or remove the ventilation in standby, click on this button, and confirm the message displayed.

3.2.5 Lock

When the screen is blocked, the padlock icon will be displayed. To activate this function, see chapter 2.4 Components of transport ventilator, item 6.

3.2.6 Alarms and messages

Alarms and alert messages will appear on this area when enabled.

3.2.7 Battery status

The remaining battery charge will be displayed on this icon.

3.2.8 Bar graph

The bar graph will show the instantaneous pressure in the breathing circuit and the value of maximal inspiratory pressure at the top.

3.2.9 Set parameters

The available set parameters will be displayed on this area. To change the parameter, click on the desired parameter, adjust the value with the knob and click to confirm.

3.2.10 Graphic area

In this area will be displayed the graphics: flow and pressure (3.2.10.9), flow and volume (3.2.10.8) or loop (3.2.10.4), or the monitoring parameters: Volume tidal, Maximum pressure, PEEP, minute volume, respiratory rate, and FiO₂ (3.2.10.7), or inspired volume, inspiratory time, plateau pressure, I:E ratio, and expiratory time (3.2.10.6), or static compliance, dynamic compliance, and resistance (3.2.10.5) or Pipeline pressure, and O₂ consumption (3.2.10.3).

To change the graphic displayed, click on the graphic area. A menu will be displayed, and it will be possible to choose other graphic or monitor. In this menu is also possible to set the alarms (3.2.10.1) and enter on CONFIG tab (3.2.10.2).

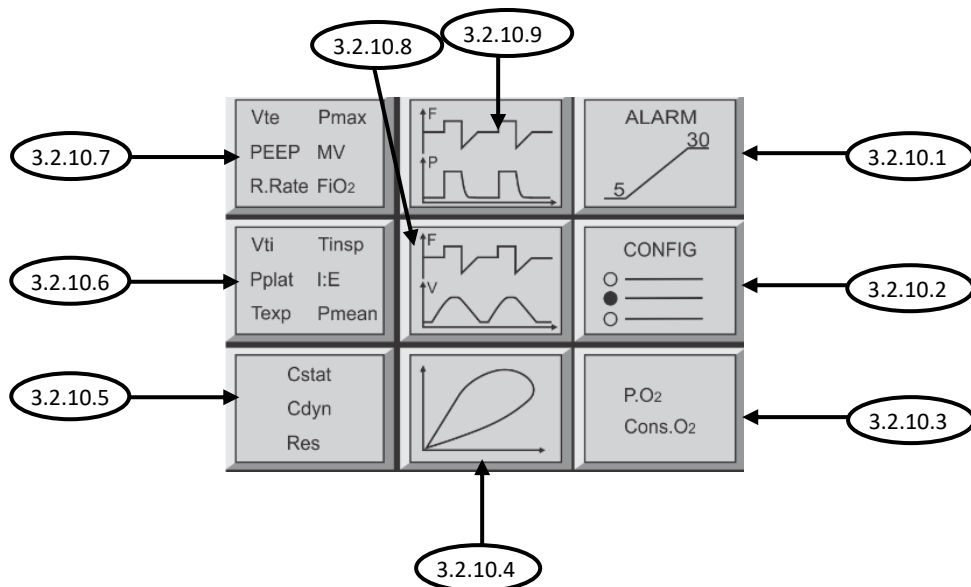

3.2.10.1 Alarm menu

By accessing this menu, it is possible to set the alarm limits. To access the ALARM menu, press anywhere on the graph screen and select ALARM.

It will be displayed the alarm limits of Pressure, Volume, PEEP, FiO₂, Minute Volume, Respiratory Rate, and Apnea Time. To set the limits, click on the area corresponding to the alarm that you want to set, turn the knob to change the parameter and press the knob to confirm.

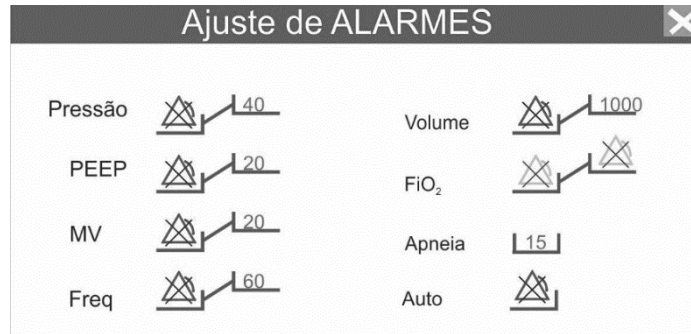

3.2.10.2 CONFIG menu

Additional configurations may be selected by pressing on the CONFIG button. To access CONFIG menu, press anywhere on the graph screen and select CONFIG. This screen is divided into three tabs:

- In the **GENERAL tab** it is possible to:
 - Change the height of the Patient thereby defining the ideal weight (BMI 22), recalculating the default ventilatory parameters of the patient.
 - Turn on or off the NIV (Non-Invasive Ventilation) using a mask. When NIV is activated, there will be compensation of leaks of approximately 40L.min⁻¹, depending on the ventilator settings.
 - Turn on or off the extern blender compensation. In this condition the device don't allow the FiO₂. The FiO₂ adjustment will be done directly in the blender¹.
 - Turn on or off the “sigh” function. In this condition, there will be a “sigh” every 100 cycles in control modes. VCV and V-SIMV – sigh add 50% of set volume.
 - Select the language of the equipment (English, Portuguese, Spanish).
- In the **O₂/CO₂ tab** it is possible to calibrate the O₂ cell and the CO₂ sensor.
 - Press button “Calibrate FiO₂” to calibrate the oxygen sensor. Calibration can be performed at one of two reference points: 21% (ambient air) or 100% oxygen. The system will automatically carry out the process, and the readings must be visually confirmed on the display. If any failure occurs during the procedure or if instability is detected in the oxygen cell, the equipment will display a fault message, since calibration is only completed when the O₂ concentration values are validated as stable at 21% (ambient air) and/or 100% (oxygen), according to the selected procedure.
 - Press button “Calibrate CO₂” to calibrate CO₂ sensor.
- In **VENTILATOR tab** it is possible to:
 - Set Audio volume – to set the alarm audio volume. Use the knob to change and confirm to make this adjustment. This parameter always starts in the maximum of 5.
 - Set the unit of Pressure – Select the desired unit (cmH₂O, hPa or mbar);
 - View data of the last test performed: breathing system leakage, compliance and resistance done in the initial tests;

¹ With extern Blender it is possible to adjust the FiO₂ from 21 to 100%.

- View the total hours of use of the equipment;
- View the hours since the last maintenance.



4. Preparation for Use

4.1 Assembling Oxymag – Transport Ventilation

Table 6 describes the steps to be followed by the operator (health care professional, duly trained and authorized to use the equipment) to assemble and prepare the transport ventilator.

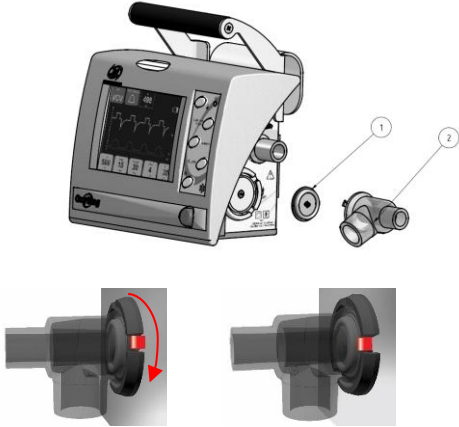
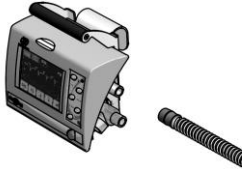
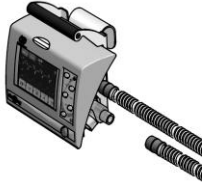
Table 6: Assembly Sequence of Oxymag

Assembly Sequence	OK	Figure
<p>1. Insert the ambient air filter into the appropriate slot on the left side of the ventilator. See chapter 11.5 Replacing the Ambient Air Filter.</p>	<input type="checkbox"/>	
<p>2. Insert a diaphragm in the exhalation valve, then insert the assembly into the base as shown in the figure and press firmly and rotate clockwise to lock.</p> <p>Attention</p> <ul style="list-style-type: none"> To unlock the valve, press the locking valve and turn the valve counterclockwise. 	<input type="checkbox"/>	
<p>3. Prepare the patient breathing circuit, firmly connecting the inspiratory limb to the flow mixing gas supply.</p>	<input type="checkbox"/>	
<p>4. The expiratory limb of the circuit should be securely connected to the exhalation valve.</p>	<input type="checkbox"/>	

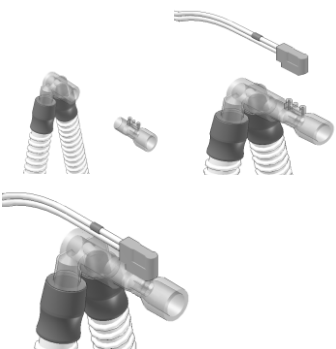
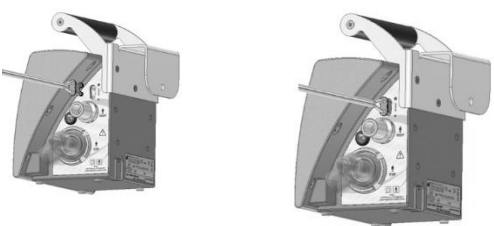
Assembly Sequence	OK	Figure
5. Connect the power supply AC/DC to the equipment then to the mains.	<input type="checkbox"/>	
6. Connect the oxygen hose to the transport ventilator.	<input type="checkbox"/>	
7. Connect the appropriate flow sensor to the patient according to the figure.	<input type="checkbox"/>	
8. Connect the flow sensor line as indicated in the figure on the right.	<input type="checkbox"/>	

Note

- There is an indication with a larger circle and a smaller circle in the ventilator showing the fitting position of the pressure line connector in the equipment.
- There is no specific position for the disposition between the operator and the patient, if the breathing circuit is mounted properly.
- For electrical insulation of the ventilator circuits from the external source, just disconnect the power supply input +12VDC from the equipment.

4.2 Noninvasive ventilation mask

Use of the breathing circuit for NON-INVASIVE VENTILATION (VNI or NIV – Non-Invasive Ventilation).

A. Without HME filter.



Figure 6: Assembly of the non-invasive mask without HME filter

B. With mask and HME filter



Figure 7: Assembly of non-invasive mask with HME filter

WARNING

- **Use HME Filter and MASKs specified by MAGNAMED use appropriate MASKs for each type of patient.**
- **Position correctly the diaphragm and the exhalation valve to prevent obstruction of the expiratory limb.**
- **The correct connection of the pressure outlet tubes, and the absence of obstruction are extremely important for the proper functioning of the patient's ventilation monitoring and, therefore, it should be checked frequently during the course of ventilation of the patients.**
- **Never obstruct pressure port. The measured pressure in these points is used by the patient ventilation monitoring system.**
- **All connections must be FIRMLY secured to prevent leakage.**
- **Only use parts, pieces and accessories specified by MAGNAMED listed in this manual, which have been tested and approved for use in conjunction with this equipment; otherwise, it can jeopardize the operation endangering the patient or user.**
- **PROPER connection of these pressure line tubes is extremely important for monitoring patient ventilation.**
- **When using OxyMag for extended time in battery, an alarm occurs which**

message is LOW BATTERY, provide IMMEDIATE connection of power supply to the mains, if DISCONNECTING the equipment from the patient is not possible and provide appropriate means of ventilatory support.

- *Use the appropriate breathing circuit to the patient.*

- *When using oxygen cylinder, check if the pressure reducing valve is set to deliver oxygen flow with pressure according to 14.3.2 Connecting to the Oxygen Supply. Pressures greater than specified may damage the equipment.*

4.3 Power Connection

The equipment must be connected to a three-pin grounded power outlet according to international standard.

The internal battery of the equipment must always be charged and ready for use in a failure of the mains or for use in external operations; for such, your power supply should be connected to the mains to charge the battery even if the equipment

remains off.

After prolonged use of the equipment, using only the energy of the internal battery, full recharge is required preparing the equipment for the extended use.

If the equipment remains unplugged for more than a month, the battery should be fully recharged.

Caution

- Do not position the equipment so that it is difficult to operate the device from disconnecting of the power supply.

Note

- After the power supply has been interrupted and restored while the internal battery is charged with the equipment is operation, the equipment performance will not be affected, and accuracy will be maintained.
- After a long period of interruption to the power supply, connect the equipment to the mains, switch on the equipment and wait 30 min. Perform necessary calibrations and self-test.

4.4 Assembling the supports

4.4.1 Assembling the vertical support

Support (1702496) is an optional item and can be used in ambulances or walls of hospital environment facilities (emergency, post-anesthetic recovery rooms, ICU, etc).

Below is provided the sequence to assemble the support on the wall.

1. Install the fixed support with +12V DC power (3803835) on the wall (room, ambulance, etc.) using 4 screws (3003446) item 1 of the figure to the side and 4 fixing bolts (3003447), if required (item 2 of the figure).



Figure 8: Installation of the fixed support

2. To place the ventilator on the support, follow the sequence below:

- a. Pull the handle bracket on the wall, just above the fixed support.
- b. Slide Oxymag down until it clicks into place.

- c. Press the safety lock of the ventilator turning the two eccentric buttons from the top until the red dots are hidden.
- d. Make sure that Oxymag is fixed in place.
- e. To remove Oxymag, perform the reverse procedure.



Figure 9: Connection of the ventilator to the fixed support

Below is provided the sequence to assemble the support on the bench:

1. Install the fixed support with +12V DC power (3803835) on the bench using 2 screws (3003446) item 2 of the figure to the side.



Figure 10: Installation of the fixed support on the bench

2. To place the ventilator on the support, follow the sequence below:

a. Insert the handle holder in the support above the fixed support.

- b. Slide Oxymag down until it clicks into place.
- c. Activate the safety lock of the ventilator turning both eccentric buttons from the top until the red dots are hidden.
- d. Make sure that Oxymag is fixed in place.
- e. To remove Oxymag, perform the reverse procedure.

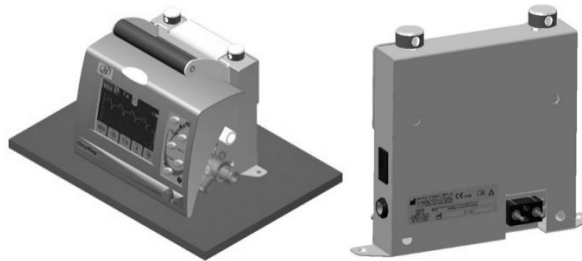

Figure 11: Connection of the ventilator to the support

4.4.2 Assembling the support for air transport

The aircraft support (1710130) is optional and can be used on fixed-wing aircraft and helicopters. The sequence for assembling the support on the aircraft fuselage is shown below.

<p>1. Install the rails to the aircraft fuselage by attaching 4 screws to each of the 4 flanges and 4 screws to each of the 2 rails:</p>	<p>2. Pull the central lock and fit the support onto the rails. Release the lock to secure.</p>
--	---

3. Replace the Oxymag handle. Unscrew the handle.

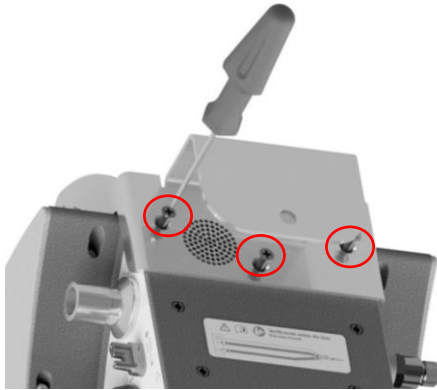

Screw the elongated handle.

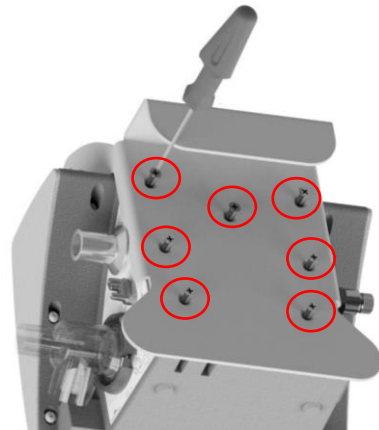

4. Position the Oxymag on the support and lower it to fit.

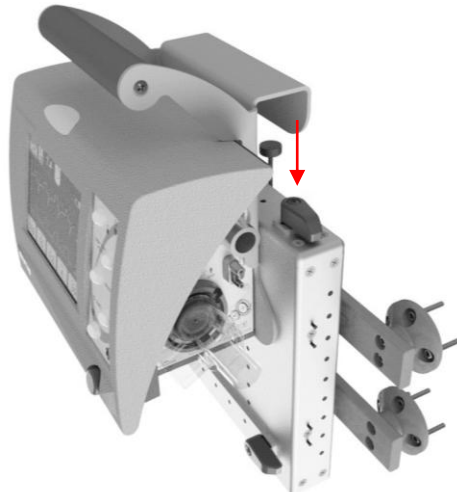

5. Rotate the 4 safety locks to secure the handle

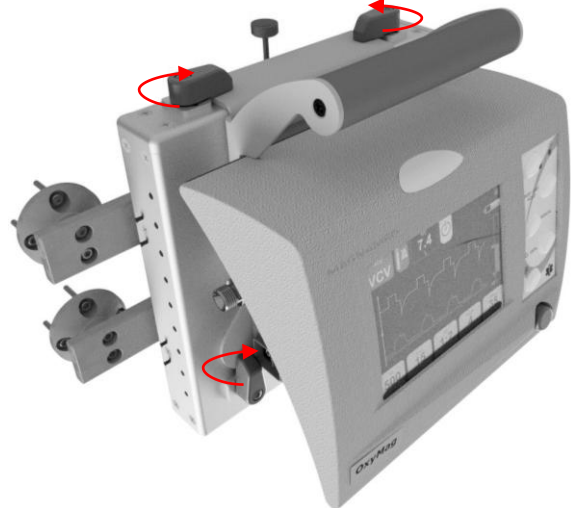

4.5 Checks Before Use

The purpose of this inspection routine is to guide the user in performing a simple and quick procedure to test the

equipment before each use or at least at the beginning of each work period.

WARNING

- ***This equipment must pass the “Checking procedures and basic settings” to ensure the effectiveness of the equipment and the safety of the operator and patient.***

4.6 Initial procedures

This equipment must pass the “Checking procedures and basic settings” to ensure the effectiveness of the equipment and the safety of the operator and the patient, as the following sequence:

- ✓ Make sure the equipment is off.
- ✓ Perform a visual inspection of the equipment and its components seeking to identify their full integrity.
- ✓ Check if all equipment components are connected and inserted correctly.
- ✓ Check the presence of the ambient air inlet filter.
- ✓ Ensure that the connection of the exhalation valve is securely connected. It is important to check the presence of the diaphragm.
- ✓ Check that the breathing circuit is securely connected and that the flow sensor is suitable for the patient to be ventilated.
- ✓ Check for the secure connection of the oxygen hose.
- ✓ Check the pressure in the cylinder gauge, where applicable this should be according to item 15.3.2 Connecting to the Oxygen Supply.
- ✓ Check for the tight connection of the power supply, where applicable. The Ventilator can be operated on battery, lasting as specified.
- ✓ Turn on the ventilator and make sure that three beeps were issued, and the alarm indicator light was triggered. This check ensures the functioning of the audible and visual alarm indicators.
- ✓ Select the type of patient with the corresponding figures shown on the display. The ventilator will immediately start ventilation. If you want to put the equipment on standby, press the button STAND-BY:



- ✓ The equipment is ready for use immediately before been turned on.

WARNING

- ***If you do not hear the triple “BEEP” signal or do not see the light flashing alarm, avoid the use of the equipment, because there will be no audible or visual indication of alarms.***

4.7 Ventilator Settings

The ideal weight of the patient is used to calculate the ventilator setting parameters to provide the best approximation to ventilate the patient. This value is calculated using the height of the patient considering the Body Mass Index (BMI) of 22. The following will be calculated according to the weight:

- Volume – calculated based on 7 mL/kg
- Frequency – according to the internal calculation to the system
- Ratio I:E - 1:2

- Inspiratory Flow – calculated according to T_{INS} obtained

The other parameters will have the default value:

- Maximum Pressure – 30 hPa (cmH₂O)
- PEEP – 5 hPa (cmH₂O)
- Plateau Pressure – 30 % de T_{INS}
- Flow – Square

The following table shows the modes available for each type of patient:

Table 7: Modes available for the types of patients

Patient type	Flow Sensor	Modes available ⁽¹⁾
NEONATAL	NEO	PLV, CPAP/PSV, P-SIMV, DualPAP
PEDIATRIC	INF	VCV, V-SIMV, PCV, CPAP/PSV, P-SIMV, DualPAP, CPR, HFOT
ADULT	ADU	VCV, V-SIMV, PCV, CPAP/ PSV, P-SIMV, DualPAP, CPR, HFOT

(1) NVI (Non-Invasive Ventilation) can be activated in all ventilation modes and when activated, it will compensate leaks (except HFOT and CPR modes)

(2) CPR and HFOT are optional for adult and pediatric patients and they are not available for neonatal patients.



Below the patient selection button, there is an indication of the sensor to be used for each patient.

WARNING

- **To obtain all monitored parameters available on the equipment, it is important to connect the correct flow sensor in the breathing circuit.**
- **If it is necessary to use a breathing circuit different from the one indicated, the correct flow sensor should still be used.**

When selecting the type of patient at the startup of the equipment, the values of ideal height and weight assumed by the equipment.

Table 8: List of values adopted by the equipment when selecting a patient

Startup button	Patient type	Height [m]	Ideal Weight P [kg]
	NEONATAL	0,36	2,8
	PEDIATRIC	0,95	19,8
	ADULT	1,50	49,5

After startup, it is possible to change the height value within the adjustment range of the patient type set by clicking on the chart area and menu and selecting the Settings button (General Tab). Setting is as table below:

Table 9: List of adjustment range for height and weight

Patient Type	Height Adjustment [m]		Ideal Weight P [Kg]
	Min.	Máx.	
NEONATAL	0,16	0,52	≤ 6,0
PEDIATRIC	0,53	1,08	6,0 < P ≤ 25
ADULT	1,09	2,5	> 25

The weight of the patient considered by the equipment is the ideal body weight, calculated according to the height of the patient. Height adjustment of the patient does not remain after turning off the equipment. It is only possible to change the height within the range of values corresponding to the type of patient selected.

WARNING

- **USE THE FLOW SENSOR INDICATED.** The correct ventilation monitoring depends on the flow sensor used in the breathing circuit.
- **Even if there is need to use breathing circuits different from the patients to be ventilated, the FLOW SENSOR SHOULD BE AS INDICATED.**

Note

- The selection of the patient type on startup will perform the initial setting of the transport ventilator and release certain ventilation modes.
- There are three types of flow sensors
 - NEO – Neonatal – Range from -20 to +20 L.min⁻¹
 - PED – Pediatric – Range from -50 to + 50 L.min⁻¹
 - ADU – Adult – Range from -150 to +150 L.min⁻¹
- Body Mass Index Formula:

$$\text{IMC} = \frac{\text{Weight [kg]}}{(\text{Height [m]})^2}$$

4.7.1 Normal Startup Sequence

1. Initial screen of Oxymag – Turn on the ventilator through on-off switch on the left side of the equipment. By turning on, note that a triple “beep” goes off in conjunction with the light alarm indicator, meaning that the audible and visual alarm are operational.

WARNING

- ***If you do not hear a triple “BEEP” sound or do not see the light alarm indicator flashing, avoid the use of the equipment, because there will be no audible or visual alarm indication.***
-

2. Press the key corresponding to the patient type to be ventilated and connect the flow sensor indicated in the patient’s breathing circuit. The ventilator will be initialized in the mode indicated in *Table 7: Modes available for the types of patients*
3. Last Adjust – This button brings back the last parameters set and saved when the equipment was switched off for the last time. This saving is automatic (optional).
4. By pressing the key NEONATAL the ventilator will start ventilation with the following parameters:

Table 10: List of parameters in the Neonatal mode

PLV	Default
Pinsp	15 cmH2O
Rate	40 min ⁻¹
Tinsp	0,5s
PEEP	5 cmH2O
Flow	6 L.min ⁻¹
FiO ₂	40%
Flow Trigger	OFF
Pressure Trigger	OFF

- By pressing key PEDIATRIC the ventilator will start ventilation with the following parameters:

Table 11: List of parameters in the Pediatric mode

PCV	Default
Pinsp	15 cmH2O
Rate	22 min ⁻¹
Ratio I:E	1:2
PEEP	5 cmH2O
FiO ₂	50%
Flow Trigger	OFF
Pressure Trigger	OFF
Rise Time	0,1s

- By pressing the key ADULT, the ventilator will start ventilation with the following parameters:

Table 12: List of the parameters in the adult mode

VCV	Default
Vt	350 mL
Rate	17 min ⁻¹
Ratio I:E	1:2

VCV	Default
PEEP	5 cmH2O
Pmax	35 cmH2O
Pause	30%
FiO ₂	50%
Flow Trigger	OFF
Pressure Trigger	OFF
Wave Flow	Square

- After the startup sequence, the equipment will display the chart screen of the ventilator. Audible alarm will be disabled in the first 2 minutes. Note that the white bar next to the alarm silencing symbol is reduced over time. After 2 minutes the audible alarm will be activated.



- Press the ventilation mode button  to display the following screen that will allow you to select the mode.
- Press the desired mode button and after confirmation of adjustment parameter required for this ventilation mode and the ventilation will immediately start.
- To change a parameter, press the corresponding button. The parameter will become YELLOW indicating that is selected, allowing the change. Turn the knob clockwise to increase the value and counterclockwise to reduce. To confirm the change, press the knob and confirm or tap on the parameter button to be changed on screen to activate the new value.

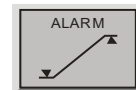

- Press ALARM button  and the Alarm Setting screen will appear, the figures below follow the order of the conditions described in the previous item. Tap on alarm to be set and use the knob and confirm to set the value. When the desired value is set confirm by pressing the knob button.

To return to the screen with the button for selection of charts, data, settings, and alarms press this button .

To automatically adjust the alarm values, select the parameter "Automatic" and select the default limit: OFF, 10%, 20% or 30%. The alarm limits of ventilator parameters (Pressure, PEEP, MV, Volume, FiO₂ and Frequency) will be automatically adjusted:

- a) In the lower limit: for the value of the parameter currently measured minus the percentage selected in automatic.
- b) In the upper limit: for the value of the parameter currently measured plus the percentage selected in automatic.

c) If OFF is selected, these alarms return to the alarm default values for the type of patient set at startup.

To enable the automatic adjustment, it is required that the ventilator is not in STAND-BY.

12. Press the screen on chart area and menu. A panel of buttons will be displayed for selection of charts, data, settings, and alarms. If no external sensor is connected to the equipment (capnography or oximeter) the respective button will not appear.

1 With extern Blender it is possible to adjust the FiO₂ from 21 to 100%.

Note

- It is not necessary to discard calibration gases.

4.7.2 Test Sequence

The tests are essential to check if the equipment is operating as expected and make adjustments for the best possible performance. Remember to conduct initial tests before starting ventilation.

WARNING

- ***Test Sequence must be performed with the patient disconnected.***

1. Home screen - Press the Test button and the sequence of internal tests will be activated. Follow the instructions on the screen.
2. Upon entering the home screen of the test sequence, you should hear a sequence of "beeps" in conjunction with the lighting of the light alarm indicator. If you do not hear the audible signal or do not see the light signal above the liquid Crystal display, press key NO; otherwise press YES to proceed to the next test.
3. By pressing the key "NO", the message: "Inoperative Device" – Contact Technical assistance will appear. The equipment requests the clearance of y-connector and the sensor connection corresponding to the last patient ventilated. Press Ok when this condition is carried out.

WARNING

- ***After a ventilation, to change the patient type in the test sequence, restart the equipment, select the type of patient desired and restart the equipment again, only then proceed to the test sequence.***

4. Tests will be carried out sequentially; after each item, there is a report of pass (OK message) or fail (Failure message).

WARNING

- ***If any test shows **Failure** perform the required repair (see table 13)***

-
5. After the test phase of the proximal sensor, press NEXT to continue.
6. Occlusion of the breathing circuit in the “Y” after the flow sensor will be requested. Press OK to confirm that the circuit is properly occluded.

Make sure that all the test items are APPROVED and check if the data for compliance, breathing circuit resistance and leakage value are suitable for use in the ventilator.

7. Press key END to complete.
8. The system will automatically return to the home screen of the ventilator. From this point on, proceed with the normal startup of the ventilator.

4.7.3 Failure Diagnosis

The *Table 13*: shows the actions that can be taken to remedy the shortcomings indicated in the test sequence. The consequence column indicated what may occur if the equipment is used with failure.

WARNING

- ***If “Inoperative Device” is indicated, the use of equipment with the presence of this failure is expressly not allowed; you should then contact the technical service to solve the problem.***

Note

- After performing repairs, you should restart the equipment and perform the sequence test again; if fault persists, contact technical assistance.

Table 13: Indications of fault diagnosis

Fault	Action	Consequence
O ₂ Flow	Ensure that the oxygen supply pressure is according to the specification 15.3.2 Connecting to the Oxygen Supply	Lack of flow, use not allowed
Internal Sensor	Contact Technical Assistance	Failure in flow control, use not allowed
Ar Flow+ O ₂	Ensure that the oxygen supply pressure is according to the specification 15.3.2 Connecting to the Oxygen Supply	Lack of flow, use not allowed
O ₂ Cell	Contact Technical Assistance	No warranty for O ₂ meter, use not allowed
Exhalation Valve	Check the positioning of the membrane in the Exhalation Valve	Failure in the pressure monitoring and control, use not allowed
Pressure Sensor	Check the positioning of the membrane in the Exhalation Valve, check leakage in breathing system	Failure in the pressure monitoring control, use not allowed
Proximal Sensor	Check connections of breathing circuit and flow sensor	<ul style="list-style-type: none"> - Message "Sensor OFF" will be displayed when connection of this sensor is not identified. - There will be variation of up to 10% in the volume measures delivered. - Only monitored the parameters: Pmax, PEEP, Pplat., Pmean and Pressure x time chart. - Parameter flow trigger will be inactive;

5 Capnography Sensor (EtCO₂)

The mainstream sensor IRMA™ MASIMO was designed to monitor the respiratory gases of adult, pediatric and infant patients during anesthesia in places such as Intensive Care Unit (ICU), Operating Rooms and Emergency Room. The CO₂ sensor is state of the art, in an assembly formed by a single way sensor with technology of up to 9 non-dispersive infrared (NDIR) channels to identify gas, a barometric pressure sensor, a voltage regulator and a microprocessor. The unit weighs less than 25g. Carbon Dioxide (CO₂) concentrations are monitored together with other parameters, such as Respiratory Rate ("RR"), the waveform of the gas and concentration of each gas during inspiration and expiration.

The IRMA airway adapter fits perfectly to the IRMA gas sensor. This equipment uses window technology XTP™. The airway adapter should be positioned between the endotracheal tube and the breathing circuit allowing that XTP Windows positioned on the sides of the sensor to measure the concentration of gases.

By operating on a standard continuous voltage of low intensity, the CO₂ sensor was designed to meet requirements of portability and low power consumption, typically below 1 Watt. It was designed to be extremely easy to integrate with any monitoring device, allowing real-time visualization of Information about gases.

5.1 Instructions for Use

The mainstream sensor IRMA was designed to be used connected to Oxymag ventilator and any other monitoring device compatible with this sensor. It has the function to monitor in real time the signal and the gas concentration.

The sensor must be connected to the patient breathing circuit in order to monitor the inhaled and exhaled gases during anesthesia, and when the patient is in the recovery room and on respiratory care. It should be used in Operating Rooms, Intensive Care Unit (ICU), Emergency Room and patient rooms. It is indicated for adult, pediatric and infant patients.

It should not be used as the sole means for patient monitoring. It should always be used in conjunction with other monitoring equipment of vital signs and this monitoring must be accompanied by an expert capable to analyze the patient condition. The CO₂ sensor was designed to be used by trained and authorized health care professionals.

5.2 Assembling the Sensor

The following steps show how to assemble the gas monitoring sensor:

- a) Connect the cable of the CO₂ sensor to the ventilator Oxymag and turn on the device.

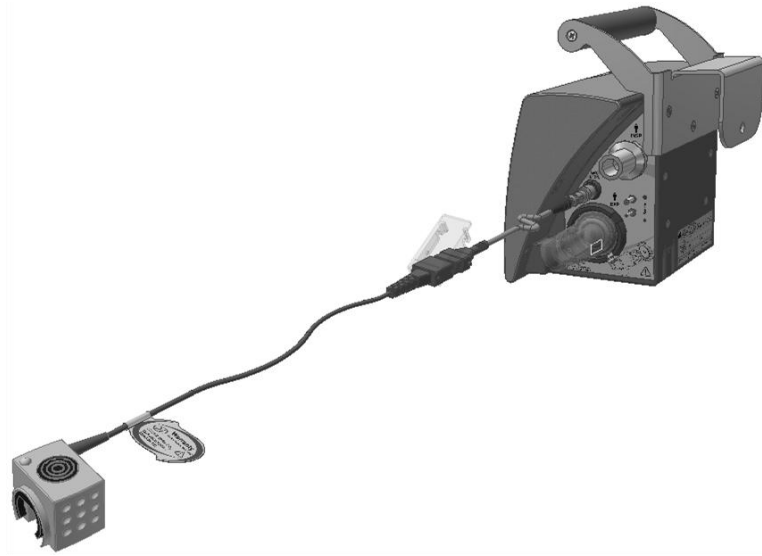

Figure 12: Fitting the capnography in OxyMag

- b) Attach the airway adapter to the IRMA sensor. You can hear a click when the airway adapter fits correctly to the sensor.



Figure 13: Fitting airway sensor

- c) green LED indicates that the CO2 sensor is ready for use.



Figure 14: LED indicates if the sensor is ready for use

- d) Connect IRMA 15-mm adult airway adapter to the flow sensor in the breathing circuit.

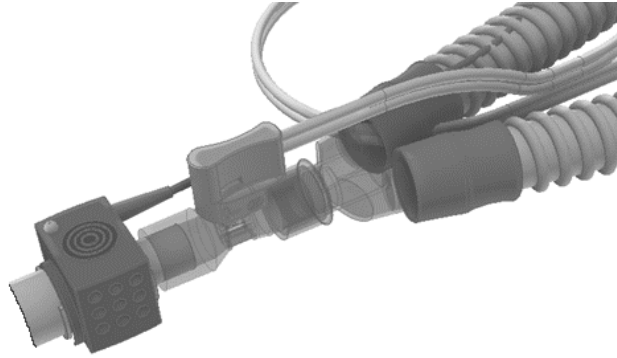

Figure 15: Connection of the airway adapter to the flow sensor of the breathing circuit

- e) Connect IRMA 15-mm adult airway adapter to the Endotracheal Tube of the patient.
- f) If there is need to connect a Heat Moisture Exchanger (HME), place it between the CO₂ sensor and the Endotracheal Tube. Placing the Moisture Exchanger in front of the sensor will protect the airway adapter from secretions and effects of steam, which eliminates the need to replace the adapter in use.

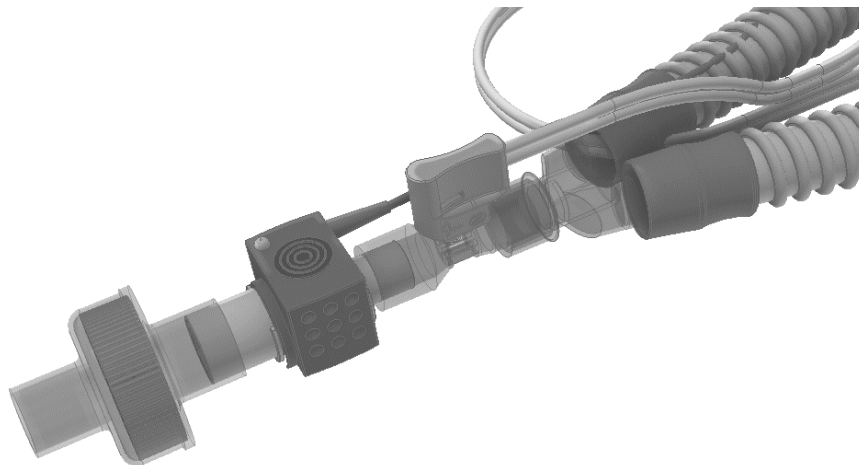

Figure 16: Scheme to assemble the Humidifier Filter

5.3 Positioning the Sensor

When connecting the CO₂ sensor to the breathing circuit of a pediatric patient, it is extremely important to avoid direct contact between the CO₂ sensor and the patient's body.

If not possible, for any reason, the direct contact of the sensor with any part of the child's or patient's body, an insulating material must be placed between the CO₂ sensor and the body.

WARNING

- *The CO₂ sensor must not have direct contact with the patient during use.*

5.4 Procedure to Reset the Sensor**WARNING**

- *The incorrect reset of the sensor will result in incorrect Reading of the measured values.*

To ensure high accuracy in the values measured by IRMA sensors, the following resetting recommendations should be followed.

Resetting must be performed by connecting an airway adapter to IRMA sensor, without connecting them to the breathing circuit. When the gas monitoring signals have stable values, press the button to start resetting.

Special care must be taken to avoid any breathe near the sensor before or during resetting. The presence of ambient air (21% O₂ and 0% CO₂) in the airway adapter is of extreme importance for a successful resetting. If the error message "Recalibration required" appears immediately after the end of the resetting, this procedure must be repeated.

Resetting must be performed every time the airway adapter is replaced. It should be also performed whenever there is a shift of the baseline (offset) in any of the gas measures or when the error message "Accuracy of gas measures not determined" appears on the screen.

After turning on the sensor or replacing the airway adapter, wait at least one minute before starting the resetting procedure in order to allow heating of IRMA sensor. The green LED on the sensor will flash for 5 seconds while resetting process is in progress.

5.5 Information regarding LED

The following table shows the possible colors displayed on the LED found on the sensor and their meanings:

Table 14: Colors on the LED and their meanings

Color (Status)	Meaning
Green (lit constantly)	System OK
Green (flashing)	Resetting in progress
Blue (constantly lit)	Anesthetic Agent Found
Red (lit constantly)	Error in sensor
Red (flashing)	Check the adapter

5.6 Preventive Maintenance of EtCO₂ Sensor

The gas calibration must be checked at regular intervals by reference instrument.

WARNING

- *The CO₂ sensor is intended for the exclusive use of trained and authorized medical personnel.*
- *The CO₂ sensor should not be used with flammable anesthetic agents.*
- *The CO₂ airway adapters should not be reused. The reuse of a disposable airway adapter may cause cross infection.*
- *Do not use the Adult/Pediatric airway adapter in pediatric patients, because the adapter adds a 6-ml dead space in the patient breathing circuit.*
- *Do not use the Pediatric airway adapter in adult patients, because this adapter may add excessive resistance.*
- *Measurements can be affected by Radio Frequency communication equipment or by mobile devices. The user must make sure that the sensor is used in environments according to the electromagnetic environment specifications expressed in this manual.*
- *Do not connect the airway adapter between the Endotracheal Tube and the elbow of the breathing circuit, as this may cause the patient secretion to block the Windows of the adapter, causing improper sensor operation.*

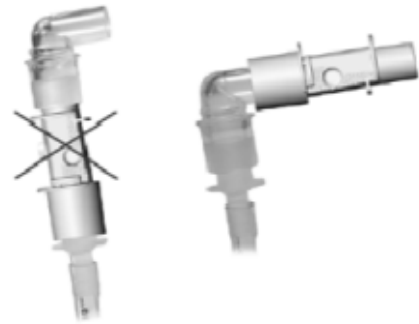

Figure 17: Incorrect and correct positioning of the airway adapter

- *Do not use the airway adapter with inhaler with dosimeters or nebulized medications, because they can affect the light transmission within the sensor window.*
- *The CO₂ sensor was designed to be an adjunct device in patient monitoring. Its information must be analyzed together with other measurements and symptoms.*
- *Improper resetting can result in erroneous measurements.*
- *Replace the airway adapter if there is condensation inside the adapter.*
- *Use only airway adapters produced by PHASEIN.*
- *The CO₂ sensor should not come into direct contact with the patient during use.*

Caution

- Never sterilize or immerse the CO2 sensor in liquid.
- Do not apply voltage to the sensor cable.
- Do not use the CO2 sensor in environments which specifications are outside the limits established in the Technical Specifications (Temperature, Humidity, etc.)
- Airway adapters of the CO2 sensor are non-sterile accessories. Steam sterilization can damage these accessories.
- Never sterilize or immerse the CO2 sensor in liquid.

5.7 Technical Specifications of the Capnography

Table 15: Technical Specifications of the Capnography

Attribute	Specification
GENERAL	
Description	Mainstream monitoring sensor with infrared technology.
Dimension (W x D x H)	IRMA CO ₂ : 38 x 37 x 34mm (1.49" x 1.45" x 1.34")
Cable length	2.50m (± 0.02m)
Weight	< 25g (without cable) < 38g (with cable)
Mechanical Resistance	Withstands repeated 1-m falls on a hard surface. According to the standard requirements for ambulances (EN 1789 – clause 6.4) and requirements against shock and vibration (ISO 80601-2-55).
Electric Power Supply	IRMA CO ₂ : 4.5 – 5.5 VDC, Max 1.0W (power measured with 5V and less than 350mA during 200ms).
Surface Temperature (room temperature 23°C)	IRMA CO ₂ : Max: 41°C / 106°F.
Airway adapter	<u>Adult/Pediatric (Disposable):</u>

Attribute	Specification
	Adds less than 6ml dead space. Pressure drop lower than 0.3cmH ₂ O at 30LPM. <u>Pediatric (Disposable):</u> Adds less than 1ml dead space. Pressure drop less than 1.3cmH ₂ O at 10LPM.
OUTPUTS	
Breathing Detection	Adaptive threshold, minimum 1% volume change in CO ₂ concentration.
Respiratory Rate	0 - 150bpm. Respiratory Rate is shown every 3 breaths and the average value is updated every breath.
Fi and ET	Fi and ET are shown after a breath and their averages are continually updated. IRMA CO ₂ : CO ₂ .
Waveform	IRMA CO ₂ : CO ₂ .
Diagnostic Parameters	Atmospheric Pressure, review of software and hardware, serial number.
Information	Detection of New Breath, Apnea, Check Adapter, Accuracy Not Specified and Sensor Error.
Method to calculate gas level reading	The highest CO ₂ concentration during a respiratory cycle with a weight function applied to favor values closer to the end of the cycle
CO₂ Gas Analyzer:	
Sensor	Gas analyzer with 2 - 9 NDIR (Non-Dispersive Infrared) Channels which measures in the range of 4 - 10µm. Makes correction of pressure, temperature, and interference across the spectral range.
Data Acquisition Rate	10 kHz
Data Sampling Rate	20 Hz
Calibration	Resetting recommended at each replacement of Airway Adapter. No need for specific infrared calibration.

Attribute	Specification
Warm-up	Information on the concentration is analyzed and sent every 10 seconds. Overall accuracy in measurements: 1 minute.
Rise time (at 10 l/min)	CO ₂ ≤ 90ms.
Overall System Response Time	< 1s.

Note

- CO₂ monitoring is achieved accurately 1 minute after initialization.

Table 16: Accuracy specifications of the Capnography

Precision / Accuracy of measurements (under standard conditions):		
Gas Type	Range	Accuracy
CO ₂	0 - 15	± (0.2 vol% + 2% reading)
	15 - 25	Not specified
Note: Gas concentration expressed in percent volume units.		
Precision / accuracy of measurements (under all conditions)		
Gas Type	Precision / Accuracy	
CO ₂	± (0.3 kPA + 4% reading)	
Note 1: Specification for precision is valid for any environmental condition specified, except in the cases expressed in the table below with "Effects of Gas and Steam Interference".		

Table 17: Interference specifications in the Capnography

Effects of Gas and Steam Interference:		
Gases or Steam	Gas Level	CO ₂
N ₂ O	60 vol%	--- (1 and 2)
HAL	4 vol%	--- (1)
ENF, ISO, SEV	5 vol%	+8% measurement read. (3)

Effects of Gas and Steam Interference:			
DES	15 vol%	+12% measurement read. ⁽³⁾	
Xe (Xenon)	80 vol%	-10% measurement read. ⁽³⁾	
He (Helium)	50 vol%	-6% measurement read. ⁽³⁾	
Propellant inhaler with dosimeter	Not designed for use with propellant inhaler with dosimeter.		
C ₂ H ₅ OH (Ethanol)	0,3 vol%	--- ⁽¹⁾	
C ₃ H ₇ OH (Isopropanol)	0,5 vol%	--- ⁽¹⁾	
CH ₃ COCH ₃ (Acetone)	1 vol%	--- ⁽¹⁾	
CH ₄ (Methane)	3 vol%	--- ⁽¹⁾	
CO (Carbon Monoxide)	1 vol%	--- ⁽¹⁾	
NO (Nitrogen Monoxide)	0,02 vol%	--- ⁽¹⁾	
O ₂	21 vol%	0% measurement read	5.0 vol% ⁽²⁾
	50 vol%	-2,76% measurement read.	4.9 vol% ⁽²⁾
	70 vol%	-4,67% measurement read.	4.8 vol% ⁽²⁾
	95 vol%	-7,05% measurement read.	4.7 vol% ⁽²⁾

NOTE 1: NEGLIGIBLE INTERFERENCE. INTERFERENCE EFFECTS DO NOT CHANGE VALUES IN TABLE "PRECISION / ACCURACY OF MEASUREMENTS (UNDER ALL CONDITIONS)" ABOVE.

NOTE 2: VALUE SHOWN FOR ACTUAL CONCENTRATION OF 5.0% CO₂

NOTE 3: INTERFERENCE AT THE GAS LEVEL INDICATED. FOR EXAMPLE, 50 VOL% HELIUM TYPICALLY LOWER THE VALUES READ AT CO₂ 6%. THIS MEANS THAT, IF THE MIXTURE CONTAINS 5.0 VOL% CO₂ AND 50 VOL% HELIUM, THE CO₂ CONCENTRATION WILL BE NORMALLY CALCULATED AS: $(1 - 0.06) * 5.0 \text{ VOL\%} = 4.7 \text{ VOL\% CO}_2$.

NOTE 4: ACCORDING EN ISO 2164

Table 18– Quantitative effects of moisture and condensation

Temp [C]	RH [%]	P [hPa]	H ₂ O part.pres [hpa]	Err _{rel} [%]	Err _{rel} ATPD [%]	Err _{rel} [%] BTPS
10	20	1013	2	0	-0,2	+6,0
20	20	1013	5	0	-0,5	+5,7
25	0	1013	0 (ATPD)	0	0	+6,2
25	23	1013	7,3	0	-0,7	+5,5
25	50	1013	16	0	-1,6	+4,6
30	80	1013	42	0	-4,1	+2,0
37	100	1013	63 (BTPS)	0	-6,2	0
37	100	700	63	0	-9,0	-2,8

6 Oximeter (Masimo)

The encapsulated pulse oximeter Masimo MS-2040 is a self-sufficient solution that enables the secure measurement even in motion and low perfusion to measure: SpO₂, heart rate, perfusion index and PVI. This oximeter is compatible with all Masimo LNCS® sensors. It is intended for use with neonatal, pediatric, and adult patients. In adults and pediatrics, the sensor is used on the finger, while in neonatal patients the sensor is multisite and may be used on the hand, foot or fingers and toes.

The LNCS DC-I and LNCS YI oximetry sensors were tested and validated with the USpO₂ MASIMO SET OXIMETRY CABLE and the OXYMAG equipment, in order to comply with the ISO 80601-2-61 standard.

6.1 Operation Principle

The MS board of Masimo SET® pulse oximeter is based on three principles:

- 1 Differential of oxyhemoglobin and deoxyhemoglobin absorption of red and infrared light (spectrophotometry).
- 2 Volume of arterial blood in the tissue and the light absorbed in blood changes (plethysmography).
- 3 Arteriovenous shunt is highly variable and its absorbance fluctuation by the venous blood is the most noise component during the pulse.
- 4 MS board of Masimo SET pulse oximeter as well as the traditional pulse oximeter determines SpO₂ by passing red and infrared light into a capillary bed and changing the measurement during the pulsatile cycle. Red and infrared light emitting diodes (LED) in oximetry sensors serve as light source; the photodiode serves as a photodetector.

Traditionally, the pulse oximetry assumes that all pulsations in the light absorbance signal are caused by fluctuations in arterial blood volume. It is assumed that the blood flow in the sensor region passes entirely by the capillary bed rather than via some arteriovenous shunt. Traditional pulse oximetry calculates the ratio of pulsatile absorbance (AC) in relation to average absorbance (DC) in each of the two wavelengths, 660nm and 905nm:

$$S(660) = AC(660)/DC(660)$$

$$S(905) = AC(905)/DC(905)$$

The oximeter then calculates the ratio between these two signals of arterial absorbance pulse:

$$R = S(660)/S(905)$$

This R value is used to find the SpO₂ saturation in a check table provided by the oximeter software. The values in this table are based on studies with human blood versus those from a co-oximetry laboratory in healthy adult volunteers in an induced hypoxia study.

The MS board of Masimo SET pulse oximeter assumes that the arteriovenous shunt is highly variable in the floating absorbance due to venous blood being part of the noise component during the pulse. The MS board decomposes S(660) and S(905) into an arterial signal plus a noise component and calculates the ratio of arterial signal without noise:

$$S(660) = S_1 + N_1$$

$$3S(905) = S_2 + N_2$$

$$R = S_1/S_2$$

Again, R is the ratio between two signals of pulsed arterial absorbance and its value is used to find the SpO₂ saturation in an empirically derived equation in the oximeter software. The values in the equation empirically derived are based on

studies on human blood versus those from a co-oximetry laboratory in healthy adult volunteers in a hypoxia-induced study.

The above equations are combined and a reference noise (N') is set:

$$N' = S(660) - S(950) \times R$$

If there is no noise $N' = 0$: then $S(660) = S(950) \times R$, which is the same ratio that the traditional pulse oximeter.

The MS board software scans through all possible R values corresponding to SpO2 values between 1% and 100% and generates a N' value for each of these R values. The signals S(660) and S(905) are processed for each possible reference noise N' for an adaptive cancellation correlation (ACC) which produces a power output versus possible SpO2 value as shown in the following figure, where R corresponds to SpO2=97%.

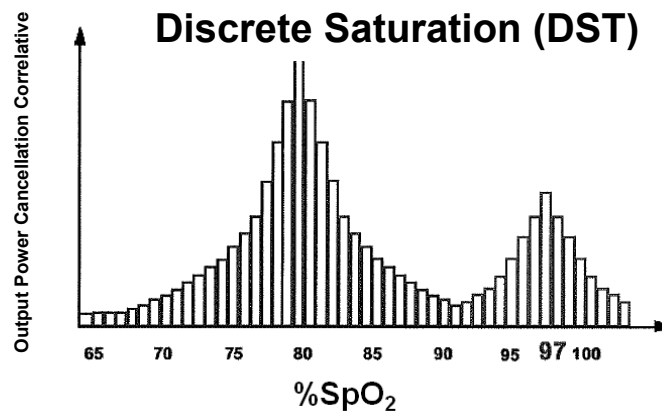

Figure 18: Discrete Saturation Curve (DST)

The DST curve has two peaks: one peak corresponding to higher saturation is selected as SpO2 value. All sequence is repeated every two seconds within the most recent four seconds of data received. Completing the SpO2 of the MS board corresponds to the analysis used for the arterial hemoglobin saturation updated every two seconds.

WARNING

- **Risk of explosion. Do not use MS pulse oximeter in the presence of flammable anesthetics or other flammable substances in communication with air, oxygen- or nitrous oxide-rich environments.**
- **The pulse oximeter should not be used as an apnea sensor.**
- **The heart rate is based on optical detection of the peripheral pulse flow and, therefore, may not detect certain arrhythmias. The pulse oximeter should not be used as replacement or substitution for the arrhythmia analysis based on ECG**
- **A pulse oximeter may be considered a previous warning device. As an indicator of tendency of patient deoxygenation, blood samples may be analyzed by a co-oximetry laboratory to complete the understanding of the patient condition.**

- ***The MS board of the pulse oximeter should be operated only by a qualified person. This manual, instructions for use, all precautionary information, and specifications should be read before use.***
- ***Risk of electric shock. Do not remove the monitor cover, except for battery replacement. The operator may perform maintenance procedures specifically described in this manual. Contact MAGNAMED technical assistance to repair this oximeter.***
- ***As with all medical equipment, position the patient cable in order to reduce the possibility of entanglement or strangling.***
- ***Interfering substances: Carboxyhemoglobin can erroneously increase readings. The level of increase is approximately equal to the amount of carboxyhemoglobin present. Dyes, or any substances containing dye, changing usual pigmentation of arteries can cause read errors.***
- ***Do not use Masimo sensor during magnetic resonance imaging (MRI). Induced current could potentially cause burns. The oximeter may affect the resonance image, and the resonance unit may affect oximetry measurements.***
- ***If the faithfulness of any measurement does not seem reasonable, first check the vital signs of the patient by alternative measures and check if the oximeter is working properly.***
- ***The oximeter may be used during defibrillation, but the readings may not be accurate by a short period of time.***
- ***Before use, carefully read the operating instructions of LNOP®/LNCS® sensors.***
- ***Use only Masimo oximetry sensors for SpO2 measurements.***
- ***Tissue can be damaged by incorrect application or use of LNOP®/LNCS® sensor; for example, by attaching too tight LNOP®/LNCS® sensors. Inspect the sensor site as directed in the instructions for use to ensure skin integrity and correct sensor positioning and attachment.***
- ***Do not use damaged LNOP®/LNCS® sensors. Do not use LNOP®/LNCS® sensors with exposed optical components.***
- ***Do not immerse the sensor in water, solvent, or cleaning solution (sensors and connectors are not waterproof). Do not use irradiation, steam or oxide sterilization. See cleaning instructions in the instructions for use of reusable Masimo LNOP®/LNCS® sensors.***
- ***Do not use damaged patient cables. Do not immerse the patient cable in water, solvent, or cleaning solution (patient cables are not waterproof). Do not use irradiation, steam, or oxide sterilization. See cleaning instructions for reusable Masimo LNOP®/LNCS® patient cables.***
- ***The responsible organization or operator shall verify oximeter compatibility prior to use, or this may result in patient injury.***
- ***Improper application of the pressure transducer with excess of pressure for prolonged periods may induce pressure damage.***
- ***Pulse oximeter is calibrated to monitor functional oxygen saturation.***
- ***SpO2 curve is not normalized.***
- ***SpO2 reading instability and unrepeatability of the waveform is an indication of signal inadequacy, which may affect the reading accuracy of the SpO2 and FC parameters and should not be reliable. The correct assembly of the sensor to the patient should be checked***

again and wait the SpO2 reading stabilized and the waveform repeatable. A functional tester cannot be used to evaluate the accuracy of a pulse oximeter.

- *The oximetry sensor presents no photobiological risk.*
- *The uSpO2 extender cable is designed for use specifically with Oxymag.*
- *The operator shall be aware of the read delay effect, considering the averaging and signal processing time that can be up to 10 seconds for the SpO2, FC and PI parameters.*
- *SpO2, FC and PI parameter readings may be affected by a delay of up to 10 seconds due to the data update period.*
- *Alarm conditions and delay in alarm generation do not affect SpO2, FC, and PI parameter readings.*
- *Depending on the selected graph, loop, or parameter screen, the read sample from SpO2 parameters will not be displayed. To perform the reading, select the SpO2 graph option. In this option it is also possible to perform readings of ventilation parameters such as airway pressure, expired volume, among others.*

Caution

- Cleaning
 - Do not sterilize by steam, pressure, or gas.
 - Do not wet or immerse the monitor in any liquid.
 - Use sparingly the cleaning solution. Excessive amount of solution may drip inside the monitor and cause internal damage to the components.
 - Do not use petroleum- or acetone-based solutions, or other harsh solvents to clean the oximeter. These components attack the materials of the device and may even result in failure.
- Inaccuracy in the measurements may have been caused by:
 - Misapplication or misuse of the sensor
 - Significant level of hemoglobin dysfunction (e.g., carboxyhemoglobin or methemoglobin).
 - Intravascular dyes, such as green indocyanine or methylene blue.
 - Exposure to excessive light, as well as surgical lamps (particularly those with xenon light source), lamp for bilirubin, fluorescent light, infrared heating lamps, or direct sunlight (exposure to excessive light can be corrected by covering the sensor with a dark or opaque material).
 - Excessive patient motion.
 - Venous pulsation
 - Positioning the sensor at one end with a blood pressure cuff, arterial catheter, or intravascular line.
- Loss of pulse signal can occur due to any of the following:
 - The sensor is too tight
 - There is excessive illumination from light sources, such as surgical lamp, bilirubin lamp or sunlight.
 - Blood pressure cuff is inflated at the same end where the SpO2 sensor is positioned.

- The patient has hypotension, severe vasoconstriction, severe anemia, or hypothermia.
 - There is arterial occlusion near the sensor.
 - The patient is in cardiac arrest or shock.
 - The oximetry sensor may be used as long as necessary.
-

6.2 Summary of Blood Calibration Test

The sensors were clinically validated for motion and no motion conditions on healthy male and female adults with light to dark skin pigmentation. SpO₂ and pulse rate measurements were made for the range of 70 to 100% SpO₂.

For the validation of no motion accuracy, hypoxia was induced in the test subjects. Test subjects were monitored with the MS-11/MS-13 pulse oximetry technology and with an ECG. Blood samples were taken for the range of 70 to 100% SpO₂ and compared against a laboratory CO-oximeter. One percent was added to the accuracies for neonatal sensors to account for accuracy variation due to properties of fetal hemoglobin.

For the validation of motion accuracy, hypoxia was induced in the test subjects while they were performing rubbing and tapping motions, at 2 to 4 Hz at an amplitude of 1 to 2 cm and a non-repetitive motion between 1 to 5 Hz at an amplitude of 2 to 3 cm.

Test subjects were monitored with the MS-11/MS-13 pulse oximetry technology and with an ECG. Blood samples were taken for the range of 70 to 100% SpO₂ and compared against a laboratory CO-oximeter. One percent was added to the accuracies for neonatal sensors to account for accuracy variation due to properties of fetal hemoglobin.

6.3 Low perfusion test summary

The sensors were validated for low perfusion accuracy in bench top testing for the range of 70 to 100% SpO₂ and a pulse rate in the range of 30 to 240 bpm. Validation was done with an MS-13 board (integrated into a Masimo SET IntelliVue Module) using the Biotek Index 2 Simulator with signal strength setting of 0.1%. SpO₂ and pulse rate measurements were successfully verified for + 2% and + 3 beats per minute (bpm) accuracies respectively.

The MS-11/MS-13 boards were validated for signal reception for very low perfusion in bench top testing, using the Masimo Simulator with signal strength setting of 0.02%. This is a small signal validation, where the board was able to recognize a minimum of 0.02% signal strength at a fixed SpO₂ setting of 83% + 2% and a fixed pulse rate setting of 80 bpm + 2 bpm. The Masimo Simulator was set at the greatest transmission setting.

6.4 Sensor assembly

Connect the oximetry sensor to the Oxymag as shown in the figure:



Figure 19: Oximeter sensor assembly

6.5 Oximeter specification

Table 19 – Performance specification

Specification criteria	Functional SpO ₂ (%)	Pulse rate (bpm)	Perfusion index (%)	PVI (%)
Display range	0.0 - 100.0 %	25 – 240 bpm	0.02 – 20.0 %	0 – 100 %
Calibration range	70 – 100 %	25 – 240 bpm	0.10 – 20.0 %	-
Calibration Standard	Invasive Co-Oximetry	ECG and Patient Simulator	Patient Simulator	-
No motion accuracy (ms)	≤ 2.0 %	≤ 3.0 bpm	-	-
Motion accuracy (rms)	≤ 3.0 %	≤ 5.0 bpm	-	-
Resolution	≤ 0.1 %	≤ 1 bpm	≤ 0.01 %	≤ 1 %
Time to display	≤ 8, ≤ 12 s	≤ 8, ≤ 12 s	≤ 8, ≤ 12 s	-
Asystole Detection Time	≤ 8 s	≤ 8 s	≤ 8 s	-
Delay	≤ 10 s	≤ 10 s	≤ 10 s	-
Response time	≤ 20 s	≤ 20 s	≤ 20 s	-
Display update frequency	≥ 1 Hz	≥ 1 Hz	≥ 1 Hz	≥ 1 Hz
Averaging time (s)	2-4, 4-6, 8, 10, 12, 14, 16	-	-	-

For each specified range, the SpO₂ ACCURACY of the PULSE OXIMETRY EQUIPMENT is determined in terms of the difference in mean square value (vqm) between the measured values (SpO_{2i}) and the reference value (SR_i), as given by the Equation:

$$A_{rms} = \sqrt{\frac{\sum_{i=1}^n (SpO_{2i} - SR_i)^2}{n}}$$

The pulse rate ACCURACY is defined over the full declared range, as the difference in mean square value (vqm) between paired pulse rate data, recorded with the PULSE OXIMETRY EQUIPMENT and with a reference method. The reference method used was a Biotek Index 2™ electronic pulse simulator.

Table 20 – Environmental Specification

Characteristic	Specification
Operation condition	
Incandescent light intensity	100 k Lux (Sunlight)
Fluorescent light intensity	10 k Lux
Fluorescent light frequency	50, 60 Hz ± 1.0 Hz
Temperature	5 to 40 °C
Humidity	15 to 95 %, non-condensing
Pressure	500 to 1060 mbar
Radiant power at 50 mA pulsed	≤ 15 mW
Storage condition	
Temperature	-40 to 70 °C
Humidity	15 to 95 %, non-condensing

Note: This information may be useful to physicians specifically.

7 Description of modes

7.1 VCV – Volume Controlled Ventilation

Description:

In this mode, the ventilator controls the volume flow and cycle, i.e., at each inspiratory cycle the ventilator delivers a precise volume to the patient, provided that the pressure is not limited. Waveform of the flow can take square, descending, sine and ascending shapes. VCV is equivalent to CMV – VC and A/C – VC of ISO 19223.

Set Parameters:

- VOLUME
- RATE
- RATIO I:E
- PEEP
- MAXIMUM PRESSURE
- PAUSE INSP (%)
- FIO2
- TRIGGER FOR FLOW
- TRIGGER FOR PRESSURE
- FLOW WAVEFORM

Note

- This ventilation mode is not available for NEONATAL patients (weight < 6,0 kg).

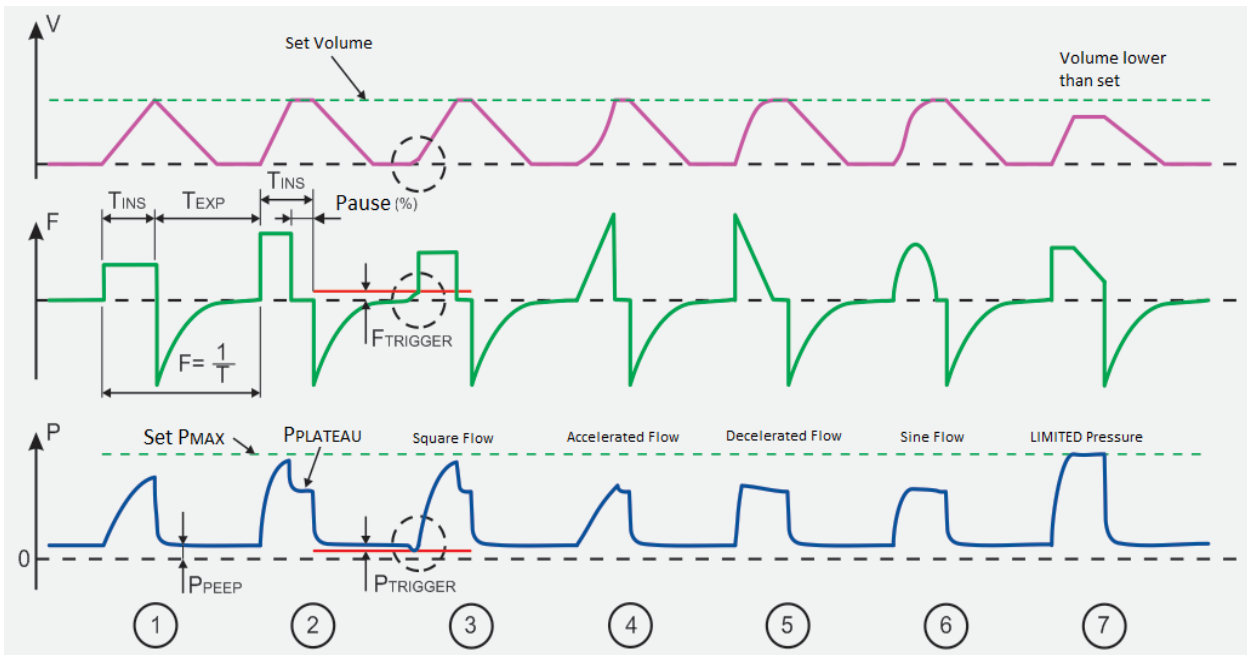

Figure 20: VCV Curves

Once all ventilation parameters are received by the ventilator, it calculates TINS, TEXP, TPAUSE, FINS based on Ratio I:E, Pause and Frequency, thus obtaining all ventilation control times.

1. Ventilation without Inspiratory Pause, after TINS the ventilator cycles to exhalation. The inspiratory pressure achieved is a consequence of the volume delivered and the resistance and compliance of the patient's breathing circuit.

2. Ventilation with Inspiratory Pause, after delivery of the set volume, the ventilator maintains the exhalation stopped until complete TINS after which the ventilator cycles to exhalation, the feature is the pressure plateau formation (gap between peak and plateau depends on the airway resistance).
3. If the pressure or flow trigger is enabled, then the ventilator tries to synchronize the beginning of the next inspiration with patient effort, according to the levels established. The information of what type of trigger activated the inspiratory cycle is reported in the area of status and messages. The detection of patient's inspiratory effort for synchronization occurs at any time of the exhalation time.

Note

- When the patient begins to demonstrate inspiratory effort and the ventilator is with flow or pressure triggers activated, it starts to “assist” the patient. This situation is often called Assisted-Controlled Ventilation.
- In assisted-controlled ventilation, the respiratory rate monitored can be higher than the respiratory rate set.

-
4. ASCENDING (or accelerated) waveform of the flow.
 5. DESCENDING (or decelerated) waveform of the flow.
 6. SINE waveform of the flow.
 7. Representation of Pressure Limitation. In this situation the ventilator limits the pressure at the set value and as a result of factors such as lung compliance of the patient and pressure limit imposed, the set volume IS NOT DELIVERED, and this condition is reported in the status area and screen messages (message LIMITED PRESSURE).

WARNING

- ***Upon reaching the pressure limit set in the Maximum Pressure setting (Message LIMITED PRESSURE) the Volume Set IS NOT DELIVERED.***
 - ***Default values are only initial reference. Reset the ventilation parameters as needed by the patient.***
 - ***Volume limited ventilators must not to be used in patients without supervision.***
 - ***In this mode, the inspiratory flow values depend on the settings of Vt, Rate and I:E. The Insp time values depend on the Rate and I:E adjustments.***
-

7.2 PCV – Pressure Controlled Ventilation

Description:

In this mode, the ventilator controls pressure, and cycles on time, i.e., at each inspiratory cycle, the ventilator reaches the set pressure and remains at this level until the inspiratory time set has elapsed, the volume is, therefore, result of the physiology of the patient’s lung (compliance and resistance). Usually when analyzing the flow curve, a flow peak is seen that decreases over time. PCV is equivalent to CMV – PC and A/C – PC of ISO 19223.

Set Parameters:

- INSP PRESSURE
- RATE
- RATIO I:E
- PEEP
- FIO2
- TRIGGER BY FLOW
- TRIGGER BY PRESSURE
- RISE TIME

Note

- This ventilation mode is not for NEONATAL patients (reported weight ≤ 6.0 kg).

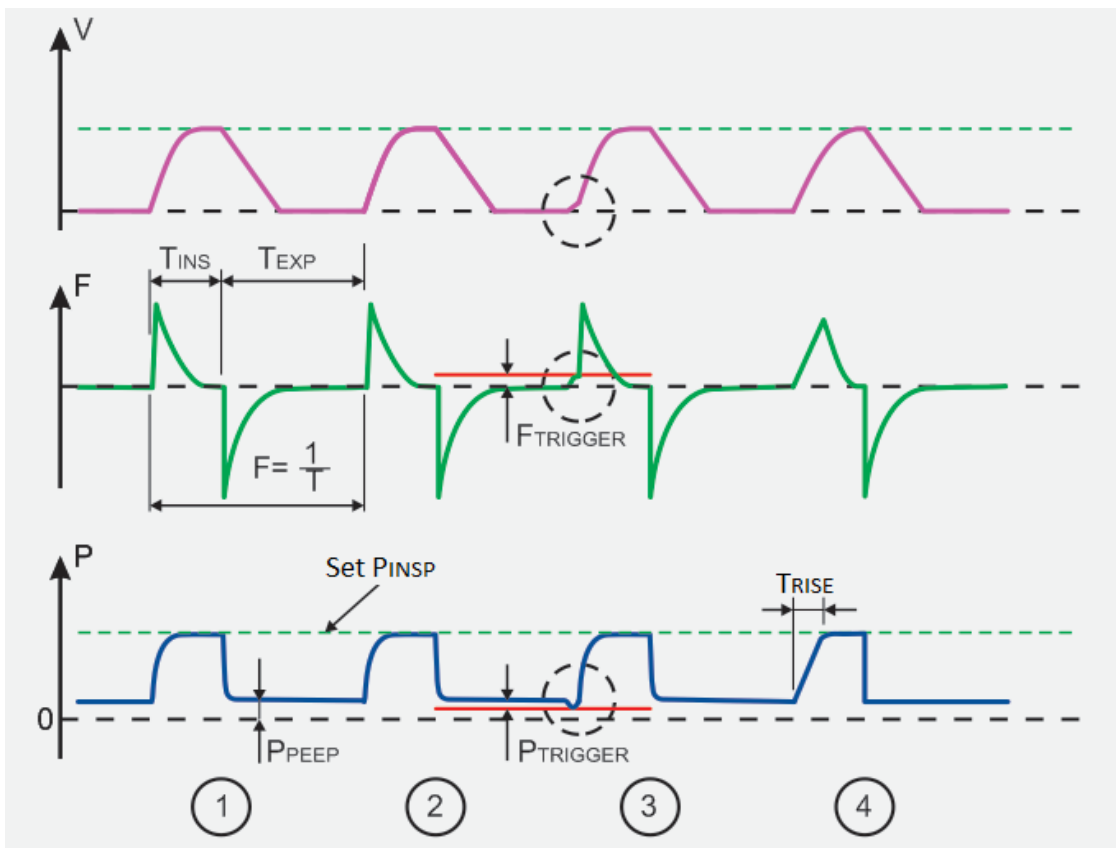

Figure 21: PCV Curves

Once all ventilation parameters are set on the ventilator, it calculates TINS, TEXP based on Rate and Ratio I:E; thus obtaining all ventilation control times.

1 and 2 Pressure Controlled Ventilation – The ventilator achieves the inspiratory pressure set in the shortest time possible, and this is accomplished by controlling the inspiratory flow. Volume delivered to the patient is the result of resistance and compliance of his breathing circuit. The ventilator remains at the inspiratory pressure level set during TINS after which cycles to exhalation, maintaining the PPE pressure set.

3 If the trigger by pressure or flow is activated, then the ventilator tries to synchronize the beginning of the next inspiration with the patient effort, according to the levels set. The information of what trigger activated the inspiratory cycle is reported in the status area and screen messages. The detection of patient's inspiratory effort for synchronization occurs at any time of the exhalation time.

Note

- When the patient begins to demonstrate inspiratory effort and the ventilator is with triggers by flow or pressure activated, it starts to “**assist**” the patient. This situation is often called Assisted-Controlled Ventilation.
- In assisted-controlled ventilation, the monitored respiratory rate can be higher than the respiratory rate set.

4 The rise time for pressure can be adjusted by TRISE TIME, the initial peak flow is generally smaller than that in TRISE TIME=0 (depending on the resistance and compliance of patient breathing circuit).

WARNING

- ***Default values are only for initial reference. Reset the ventilation parameters as needed by the patient.***
 - ***In this mode, the inspiratory time values depend on Rate and I:E adjustments.***
-

7.3 PLV –Limited Pressure Ventilation

Description:

In this continuous flow mode, the ventilator limits pressure, and cycles on time, i.e., at each inspiratory cycle the ventilator reaches the set pressure and remains at this level until the inspiratory time set has elapsed, the volume is, therefore, result of the physiology of the patient's lung (compliance and resistance). Usually when analyzing the flow curve, a flow peak is seen which decreases over time.

Set Parameters:

- INSP PRESSURE
- RATE
- INSPIRATORY TIME
- PEEP
- FLOW ()
- FiO2
- TRIGGER BY FLOW
- TRIGGER BY PRESSURE

Note

- This ventilation mode is available only for NEONATAL patients (reported weight ≤ 6.0 kg).
- The operator shall consider the patient's inspiratory time and respiratory mechanics to define the continuous flow adjustment. If the flow is not sufficient, the airway pressure may not reach the adjusted value.

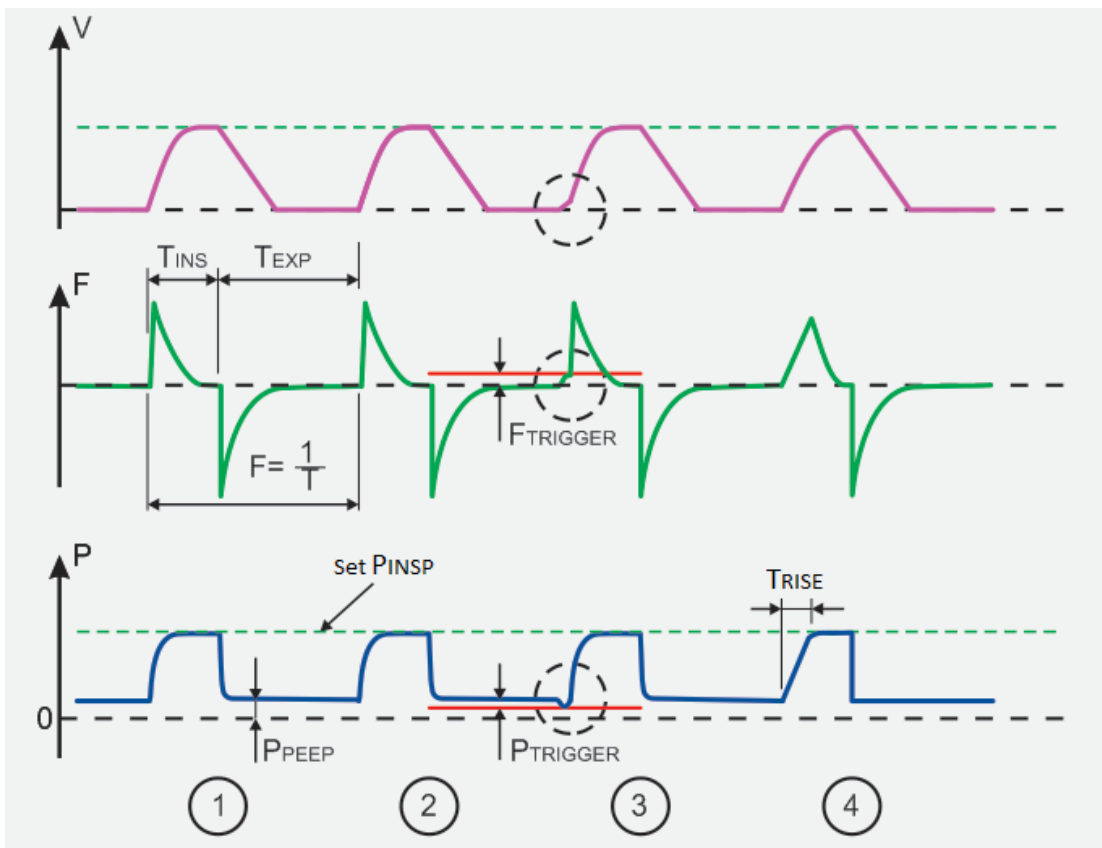

Figure 22: PLV Curves

Once all ventilation parameters are set on the ventilator, it calculates TEXP based on Rate and TINS and, thus, obtain all ventilation control times.

1 e 2 Pressure Limited Ventilation – The ventilator seeks to achieve the set inspiratory pressure, and this is accomplished by occlusion of the exhalation valve. It is important to note that the pressure rise time is dependent on the set continuous flow. The Volume delivered to the patient is the result of the resistance and compliance of his breathing circuit. The ventilator remains at the level of set inspiratory pressure during TINS after which cycles to exhalation, maintaining the set PEEP pressure.

3 If the trigger by pressure or flow is activated, then the ventilator seeks to synchronize the beginning of the next inspiration with the patient effort, according to the levels set. The information of what type of trigger activated the inspiratory cycle is reported in the message area and screen status. The detection of patient's inspiratory effort, for synchronization, occurs at any time during expiratory time.

WARNING

- ***Default values are only for initial reference. Reset the ventilation parameters, as needed by the patient.***

Note

- When the patient begins to demonstrate inspiratory effort and the ventilator is with triggers by flow or pressure activated, it starts to “assist” the patient. This situation is often called Assisted-Controlled Ventilation.
 - In an assisted-controlled ventilation, the respiratory rate monitored can be higher than the respiratory rate set.
 - BASE FLOW is an existing flow during the exhalation phase to eliminate CO₂ from the respiratory circuit, in addition to reduce undesirable PEEP.
 - In this mode, the I:E ratio parameters depend on the settings of Insp time and Rate.
-

7.4 V-SIMV – Synchronized Intermittent Mandatory Ventilation – Volume Controlled Cycle

Description:

In this mode, the patient can breathe spontaneously between the controlled cycles, with or without the use of pressure support. Controlled cycles are VCV (Volume Controlled).

V-SIMV is equivalent to SIMV-VCIPS of ISO 19223.

Note

- This ventilation mode is not available for NEONATAL patients (weight reported ≤ 6.0 kg).

Set Parameters:

- VOLUME
- RATE
- INSPIRATORY TIME
- PEEP
- MAXIMUM PRESSURE
- PAUSE (%)
- FiO2
- Δ PS (Pressure support – PEEP)
- TRIGGER BY FLOW
- TRIGGER BY PRESSURE
- WAVEFORM OF THE FLOW
- CYCLING BY FLOW (% FLOW)
- RISE TIME
- FLOW (- only to NEONATE);

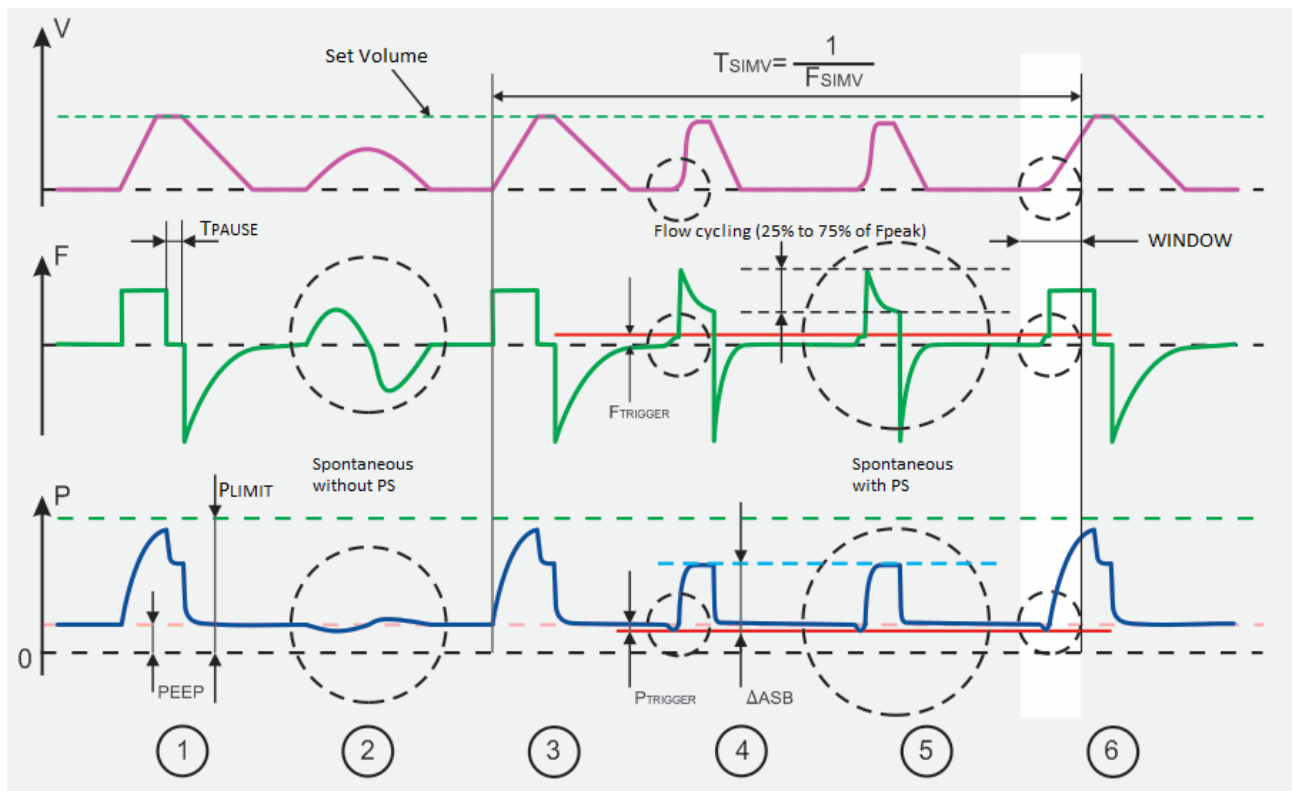

Figure 23: V-SIMV curves

Once all ventilation parameters are set on the ventilator, it calculates T_{EXP} and F_{INS} based on Inspiratory Time, Pause and Rate, thus obtaining all ventilation control times.

- 1 Represents a VCV (volume controlled) cycle with inspiratory pause.
- 2 Represents a spontaneous breathing cycle of the patient WITHOUT PRESSURE SUPPORT.
- 3 Represents a VCV (volume controlled) cycle with SIMV Period elapsed.

4 and **5** Represents spontaneous breathing cycle of the patient WITH PRESSURE SUPPORT, with cycling occurring by flow, when this reaches a value between 5% and 80% of the peak value read. Peak flow percentage at which cycling of inspiratory phase occurs to the expiratory phase is programmable. The rise time (TRISE TIME) also applies to pressure support (see PCV).

6 If the patient performs inspiratory effort, at the end of the SIMV period (TSIMV), there is a window to the timing of controlled ventilation cycle, which is 'open' from $0.75 \times \text{TSIMV}$, i.e., the last quarter of SIMV Period a timing window opens for the mandatory ventilation cycle. The information of what type of trigger activated the inspiratory cycle is reported in the message area and screen status.

Note

- Respiratory rate monitored can be higher than respiratory rate set, because the patient can breathe spontaneously during the mandatory ventilation cycles.
- Pressure support (ΔPS) is a value above PEEP and can be adjusted between 5 cmH₂O and P_{MAX}-PEEP.

WARNING

- ***Default values are only for initial reference. Reset ventilation parameters as needed by the patient.***
 - ***Volume limited ventilation must not to be used in patients without supervision.***
-

7.5 P-SIMV – Synchronized Intermittent Mandatory Ventilation – Pressure Controlled Cycle

Description:

In this mode, the patient can breathe spontaneously between the controlled cycles, with or without the use of pressure support. The controlled cycles will be PCV (Pressure Controlled). P-SIMV is equivalent to SIMV-PC/PS of ISO 19223.

Set Parameters:

- INSP PRESSURE
- RATE
- INSPIRATORY TIME
- PEEP
- FIO2
- ΔPS (Pressure Support – PEEP)
- TRIGGER BY FLOW
- TRIGGER BY PRESSURE
- CYCLING BY FLOW (% FLOW)
- RISE TIME
- FLOW (- only to NEONATE);

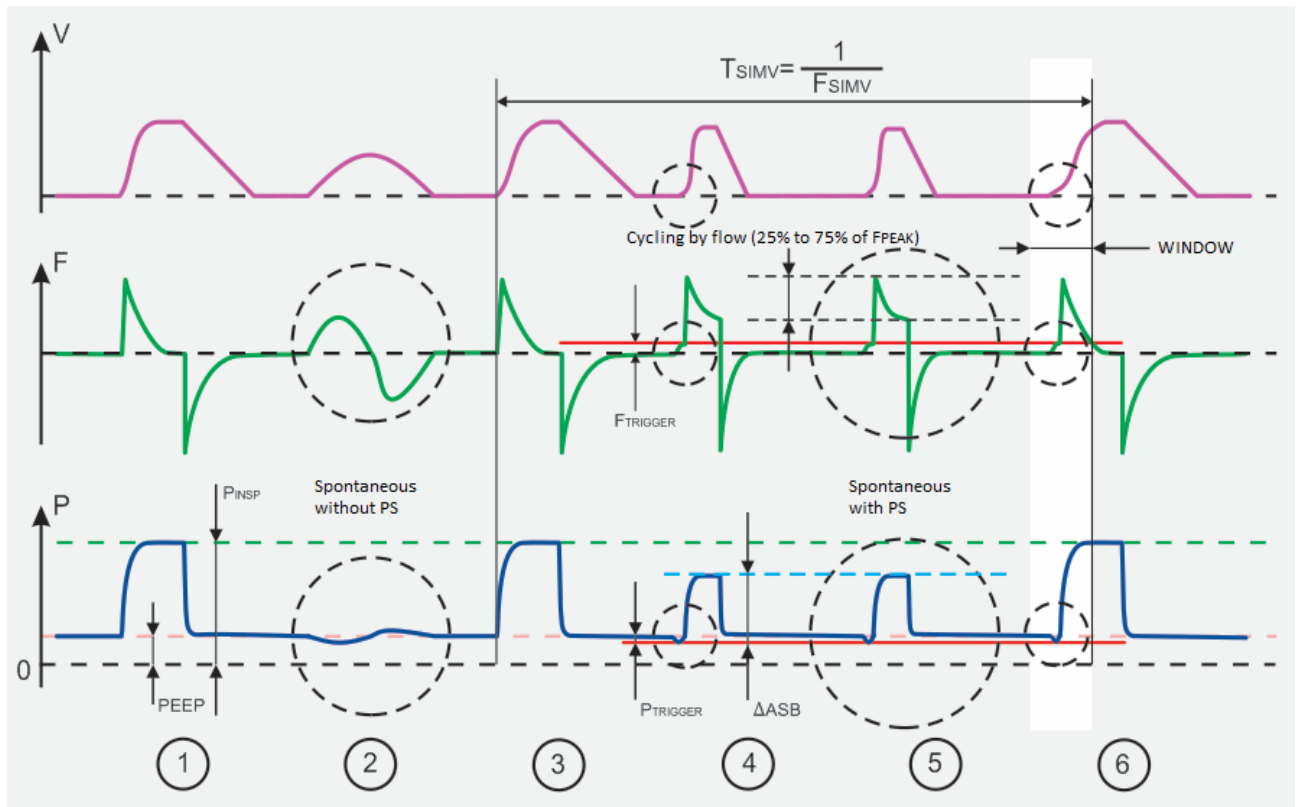

Figure 24 - P-SIMV Curves

Once all ventilation parameters are set on the ventilator, it calculates TEXP based on TINS and Rate, thus obtaining all ventilation control times.

- 1 Represents a PCV (pressure controlled) cycle during TINS
- 2 Represents a spontaneous breathing cycle of the patient WITHOUT PRESSURE SUPPORT
- 3 Represents a PCV (pressure controlled) cycle when SIMV Period has elapsed
- 4 and 5 Represents the spontaneous breathing cycle of the patient WITH PRESSURE SUPPORT, with cycling occurring by flow, when this reaches a value between 5% and 80% of the peak value read. Percentage of peak flow in which cycling occurs from inspiratory phase to expiratory phase is programmable. Rise time (TRISE TIME) also applies to pressure support (see PCV).
- 6 If patient performs inspiratory effort, in the end of SIMV period (TSIMV), there is a timing window of the controlled ventilation cycle, which is 'open' from $0.75 \times \text{TSIMV}$, i.e., in the last quarter of SIMV Period, a timing window opens for the mandatory ventilation cycle. The information of what type of trigger activated the inspiratory cycle is reported in the message area and screen status.

WARNING

- ***Default values are only for initial reference. Reset ventilation parameters as needed by the patient.***

Note

- Respiratory rate monitored can be higher than respiratory rate set, because the patient can breathe spontaneously during mandatory ventilation cycles
 - Pressure support (ΔPS) is a value above PEEP and can be adjusted between + 5 cmH₂O and PINSP - PEEP.
-

7.6 CPAP/PSV – Continuous Pressure Ventilation with Pressure Support

Description:

In this mode, the patient breathes spontaneously on a continuous positive pressure and breathing is assisted by a Pressure Support (ΔPS). Usually when analyzing the flow curve, a flow peak is seen which decreases over time.

Cycling occurs by flow, is adjustable between 5% and 80% peak inspiratory flow measured.

If the Pressure Support (ΔPS) value is set to 0 (ZERO) or both cycle trigger ways (pressure or flow) are disabled, pure CPAP mode will be activated, i.e., without pressure support. In this condition, PEEP parameter will be displayed as CPAP.

CPAP is equivalent to CPAP and CSV-PS of ISO 19223.

Set Parameters:

- PEEP or CPAP
- ΔPS (Pressure Support – PEEP)
- TRIGGER BY FLOW
- TRIGGER BY PRESSURE
- FiO2
- CYCLING BY FLOW (% FLOW)
- RISE TIME
- BACK-UP MODE (VCV, PCV, PLV-NEONATAL or WITHOUT BACK-UP)
- RATE (back-up VCV, PCV and PLV)
- RATIO I:E (back-up VCV and PCV)
- MAXIMUM PRESSURE (back-up VCV)
- VOLUME (back-up VCV)
- PAUSE (back-up VCV)
- FLOW WAVEFORM (back-up VCV)
- INSP PRESSURE (back-up PCV and PLV)
- INSPIRATORY TIME (back-up PLV)
- FLOW (- back-up PLV)

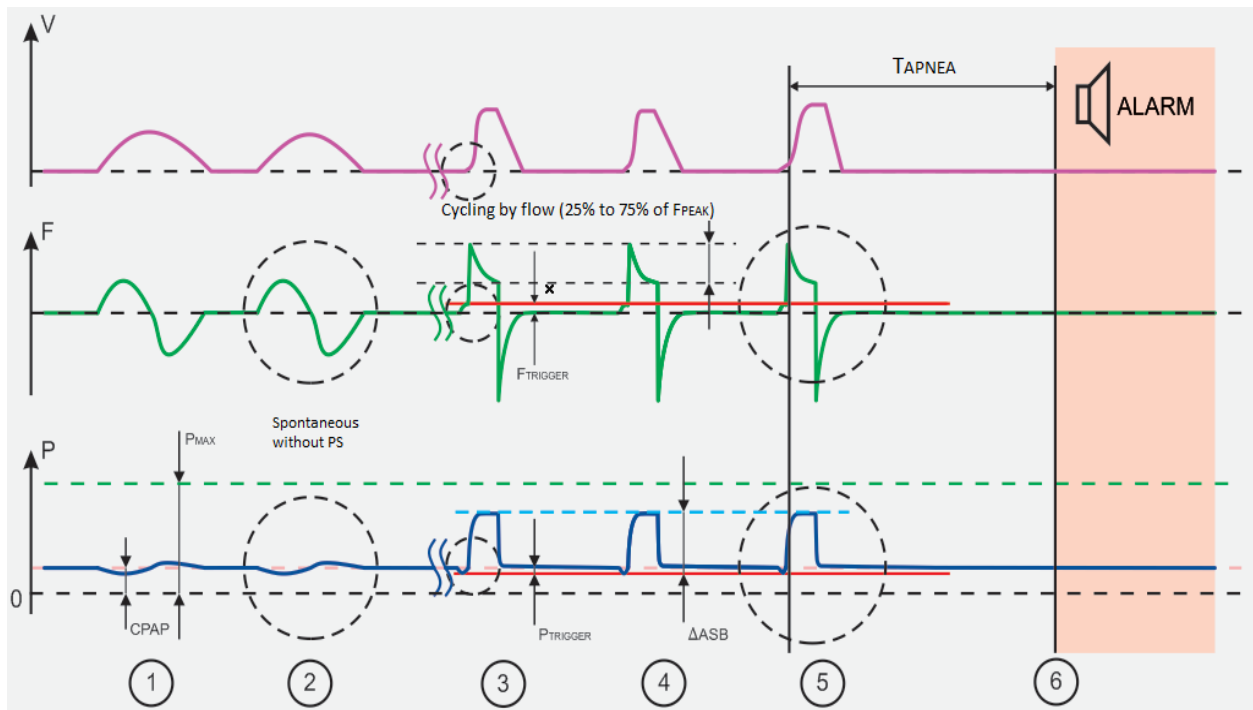

Figure 25: PSV (CPAP + ΔASB) Curves

- 1 and 2 Represent spontaneous cycles with pressure support at ZERO.
- 3, 4 and 5 Represent spontaneous breathing cycles of the patient with pressure support different from zero. TRISE TIME of pressure support may be adjusted so that initial flow is smoothed.
- 6 If the patient enters in apnea, after TAPNEA (s) the ventilator will show this condition with alarm in its message area and alarms on screen and will initiate backup ventilation selected as settings and parameters programmed.

WARNING

- ***Apnea alarm should be set to a safe value for the patient. However, apnea alarm can be RESET, in this condition, there will be no information or alarm for apnea condition and no backup ventilation in action. The equipment operator must be aware of the Apnea Alarm condition DEACTIVATED (OFF INDICATING ON DISPLAY).***
- ***If backup ventilation selected is NO BACK-UP, the equipment operator must be aware of this situation (INDICATING ON DISPLAY).***
- ***Default values are only for initial reference. Reset the ventilation parameters as needed by the patient.***

Note

- Pressure support (Δ PS) is a value above PEEP and can be adjusted between + 5 cmH₂O and P_{MAX} - PEEP.
 - To obtain CPAP mode with backup ventilation, select option CPAP/PSV, set Δ PS=OFF and select backup ventilation.
-

7.7 DualPAP – Bi-level Continuous Positive Airway Pressure Ventilation

Description:

In this mode, the patient breathes spontaneously on two continuous positive pressure and breathing may be assisted by a Pressure Support (ΔPS). Usually by analyzing the flow curve, a flow peak is seen which decreases over time. If the Pressure Support (ΔPS) value is set to 0 (ZERO) or both cycle trigger ways (pressure or flow) are disabled, pure DualPAP mode will be activated, i.e., without pressure support.

Cycling occurs by flow, adjustable between 5% and 80% inspiratory flow peaks measured. Depending on this, **APRV – Airway Pressure Release Ventilation can be obtained.**

Set parameters:

- P. HIGH
- T. HIGH
- P. LOW
- T. LOW
- FIO₂
- ΔPS (Pressure Support – PEEP)
- TRIGGER BY FLOW
- TRIGGER BY PRESSURE
- CYCLING BY FLOW (% FLOW)
- RISE TIME
- MAXIMUM PRESSURE
- FLOW (\dot{V} - only to NEONATAL)
- BACK-UP MODE (VCV, PCV, PLV-NEONATAL or WITHOUT BACK-UP)
- RATE (back-up VCV, PCV and PLV)
- RATIO I:E (back-up VCV and PCV);
- VOLUME (back-up VCV)
- PAUSE (back-up VCV)
- FLOW WAVEFORM (back-up VCV)
- INSP PRESSURE (back-up PCV and PLV)
- INSPIRATORY TIME (back-up PLV)
- FLOW (back-up PLV)
- PEEP (back-up VCV e PCV)

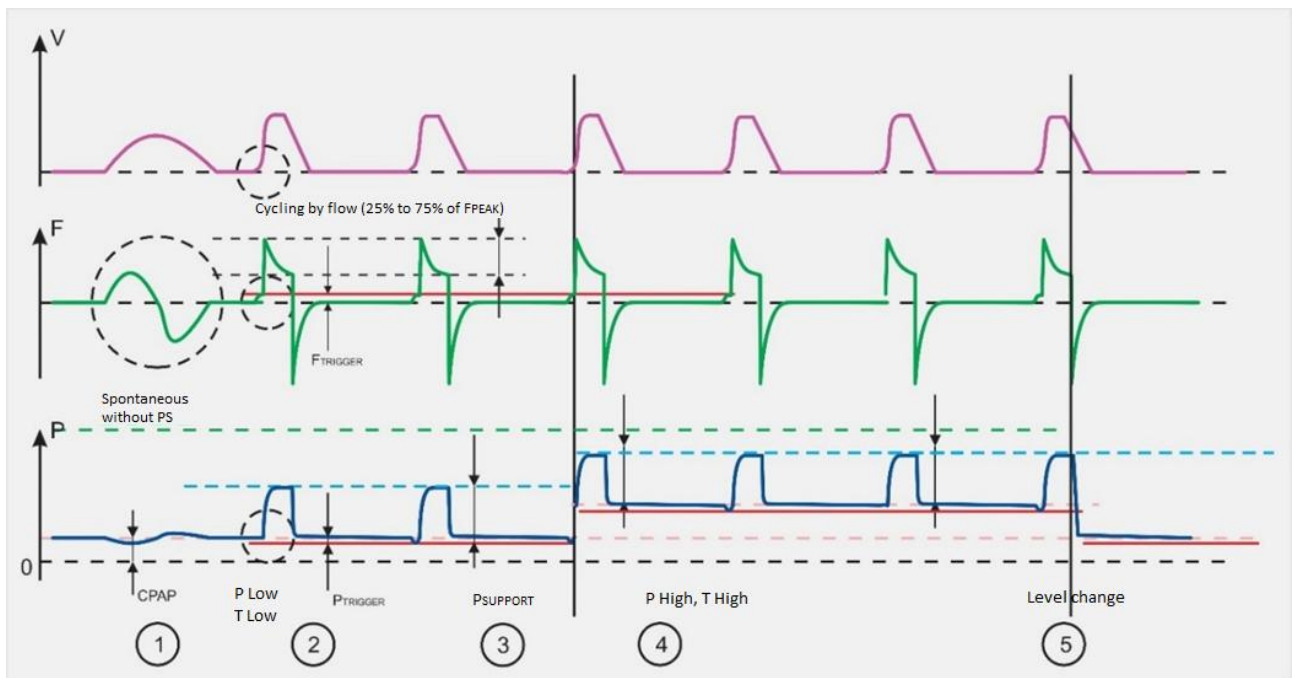

Figure 26 – DualPAP Curves

Once all ventilation parameters are set on the ventilator, the patient breathes spontaneously defining the ventilation control times.

- 1 Represents a spontaneous cycle without pressure support at P.Low (Low Continuous Airway Pressure);
- 2 Represents a breathing cycle with Pressure Support assist (above P.Low);
- 3 to 4 Represents a synchronized transition to P.High (High Continuous Airway Pressure);
- 5 Represents a transition from P. High to P. Low synchronized.

Transitions of levels from P.Low →P.High or P.High → P.Low occur in the final quarter of T.Low and T.High, respectively, by synchronizing with the effort of the patient. The information of what trigger activated the inspiratory cycle is reported in the message area and screen status.

WARNING

- ***Default values are only for initial reference. Reset the ventilation parameters as needed by the patient.***
-

Note

- Respiratory rate monitored is result of the spontaneous breathing of the patient
 - Pressure support (Δ PS) is a value above P.High or P.Low and can be adjusted between 5 cmH₂O and P_{MAX} - P_{High}.
 - Changes in pressure levels are synchronized.
-

7.8 APRV –Airway Pressure Release Ventilation (mode obtained with inverted ratio in DUALPAP)

Description:

This mode allows spontaneous cycles on 2 levels of baseline pressure and can be achieved by appropriate adjustments in DualPAP mode.

For this mode selects inverted ratio in DUALPAP. With this adjustment is carried out a pressure relief airway, obtaining APRV – Airway Pressure Release Ventilation

Set parameters:

- P. HIGH
- T. HIGH
- P. LOW
- T. LOW
- FiO2
- ΔPS (Pressure Support – PEEP)
- TRIGGER BY FLOW
- TRIGGER BY PRESSURE
- CYCLING BY FLOW (% FLOW)
- RISE TIME
- MAXIMUM PRESSURE
- FLOW (v̇ - only to NEONATAL)
- BACK-UP MODE
- (VCV, PCV, PLV-NEONATAL or WITHOUT BACK-UP)
- RATE (back-up VCV, PCV and PLV)
- RATIO I:E (back-up VCV and PCV)
- VOLUME (back-up VCV)
- PAUSE (back-up VCV)
- FLOW WAVEFORM (back-up VCV)
- INSP PRESSURE (back-up PCV and PLV)
- INSPIRATORY TIME (back-up PLV)
- FLOW (back-up PLV)
- PEEP (back-up VCV e PCV)

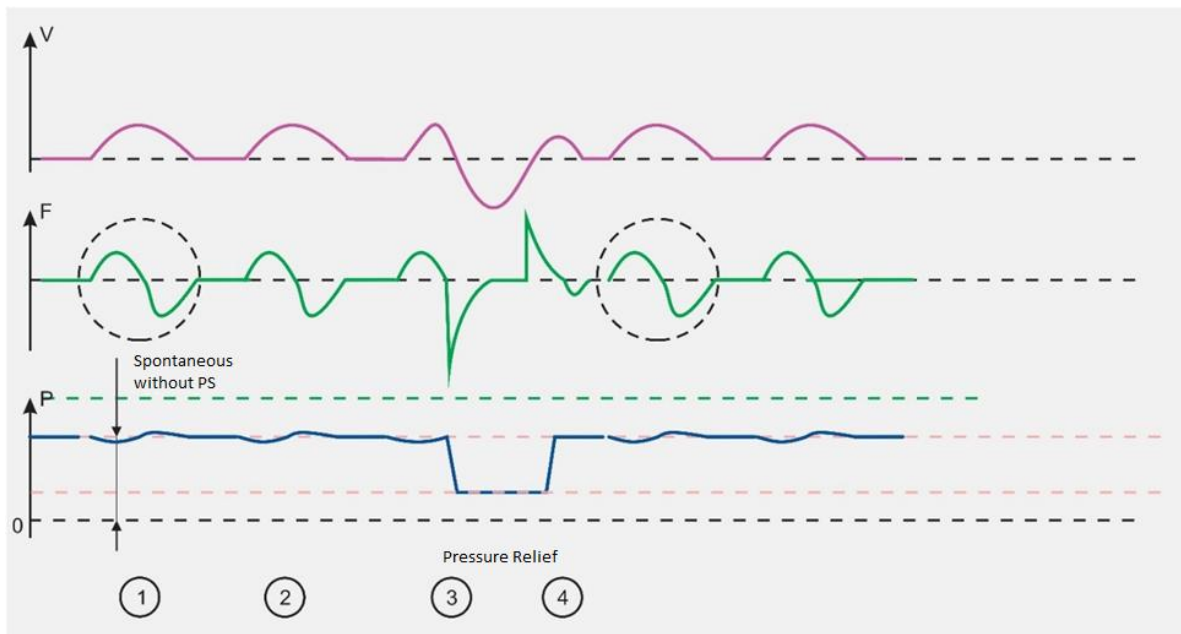

Figure 27: APRV Curves

Once all ventilation parameters are set on the ventilator, the patient breathes spontaneously defining the control times of ventilation.

- 1 and 2 Represent spontaneous cycles without pressure support at P. High (High Continuous Airway Pressure)
- 3 Represents the transition of P.High to P.Low (Low Continuous Airway Pressure) synchronously;
- 3 to 4 Represents the time T.Low in which airway pressure release is performed;
- 4 Represents transition from P.Low to P. High synchronously.

Transitions of levels from P. High → P.Low or P.Low → P. High occur in the final quarter of T. High and T.Low, respectively, by synchronizing with the patient's effort. The information of what type of trigger activated the inspiratory cycle is reported in the message area and screen status.

WARNING

- ***Default values are only for initial reference. Reset the ventilation parameters as needed by the patient.***
- ***To obtain DUALPAP mode with backup ventilation, select backup ventilation in the backup parameter.***

Note

- Respiratory rate monitored is result of spontaneous breathing of the patient
 - Pressure support (Δ PS) is a value above P.High or P.Low and can be adjusted between PMax- P.High + 5 cmH₂O e PMAX - P.High.
 - Changes in pressure levels are synchronized.
-

7.9 CPR – Cardiopulmonary Resuscitation

Description:

The CPR – Cardiopulmonary Resuscitation mode allows you to carry out cardiac compression maneuvers for the recovery of cardiac functions.

In this mode, the ventilator provides a CPAP level of 5 cmH₂O and signals the operator when to perform compression through the red light on the top of the ventilator and through the monitor screen.

During the cardiopulmonary resuscitation process, a stopwatch is displayed showing the time elapsed after the start of the procedure, the frequency of compressions, the pulmonary pressure differential during compressions and, if a capnograph is connected, the EtCO₂ measured in the breath is displayed.

To provide breathing press the MANUAL button.

Set Parameters:

- PEEP
- ΔPS
- F.Trigger: OFF
- P.Trigger: OFF
- FiO₂
- Cycl. PS
- Rise Time
- Backup: OFF

Basic protocol for adult patients:

- 30 chest compressions with a depression of 5 to 6 cm and at a rate of 100 to 120 compressions per minute (with)
- Two lung inflations lasting 1 second each (note visible chest rise).

7.10 HFOT – High Flow Oxygen Therapy

Description:

High Flow O2 Therapy (HFOT) mode allows the use of the ventilator for that therapy.

High Flow O2 Therapy is a form of respiratory support with flows of O2 and Air in combination with an active humidification system and delivered to the patient with flows greater than those traditionally provided in oxygen therapies.

Note

- It is recommended to use a heated humidifier to keep your breath moist.
- It is recommended to use a nasal cannula for high flow (HFNC – High Flow Nasal Canula).

Set Parameters:

Adult Patient:

- Flow: 0 to 60 L/min
- O2 Concentration: 40 to 100%

Pediatric Patient:

- Flow: 0 to 60 L/min
- O2 Concentration: 50 to 100%

Goals of High Flow Therapy:

- Eliminate much of the anatomical dead space
- Create an O₂ reservoir in the nasal cavity
- Improve gas exchange
- Significantly reduce the work of breathing

Other benefits of High Flow Therapy with humidifier:

- Reduction in respiratory rate
- Less dyspnea with improved comfort
- The use of heated humidification keeps the mucus more fluid and helps in the recovery of the airways

In this mode, flows from 0 to 60 L.min⁻¹ and concentrations from 40 to 100% of O₂ in adult patients and from 50 to 100% of O₂ in pediatric patients can be adjusted. FiO₂ measured by internal cell and calculation of O₂ consumption in L.min⁻¹ are monitored.

WARNING

- The humidifier shall comply with ISO 80601-2-74 and airway devices shall comply with ISO 18190:2016 and ISO 18561-1:2017.
- When using pediatric cannulas, pay attention to oxygen monitoring. The lowest concentration of O₂ delivered by the ventilator with pediatric cannulas is 50%.
- Connect the HIGH FLOW O₂ THERAPY breathing circuit with the HIGH FLOW NASAL CANNULA to the VENTILATOR'S FLOW OUTLET.
- Do not lubricate fittings, connections, tubing, or other accessories of the equipment to avoid the risk of fire and burns.
- Do not use sealed patient interfaces with this equipment, to avoid the risk of suffocation or barotrauma.
- Ensure a sufficient intended leakage between the breathing system and the patient to allow the patient to exhale.
- Do not allow open flames within 2 m of the equipment or any oxygen-carrying accessories. Open flames during oxygen therapy are dangerous and are likely to result in fire or death.
- Oxygen makes it easier for a fire to start and spread. Do not leave the nasal cannula or mask on bed coverings or chair cushions, if the equipment is turned on, but not in use; the oxygen will make the materials more flammable. Turn the equipment off when not in use to prevent oxygen enrichment.
- Smoking during oxygen therapy is dangerous and is likely to result in facial burns or death. Do not allow smoking or open flames within the same room as the equipment or any oxygen-carrying accessories. If the patient intends to smoke, always turn the equipment off, remove the cannula and leave the room where the equipment is located. If unable to leave the room, wait 10 minutes after you have turned the equipment off.
- The therapy supplied to the patient can be adversely affected by the gas added by the use of a pneumatic nebulizer.
- There is a risk of fire associated with oxygen enrichment during oxygen therapy. Do not use the equipment or accessories near sparks or open flames.
- This equipment is only suitable for a spontaneously breathing patient.
- Do not connect the equipment to the battery of a wheelchair battery-powered wheelchair as this can affect the equipment performance which consequently can result in degradation of health of the patient.
- When using the equipment in a carrying case or in-use bag, only use a carrying case or in-use bag that is listed in the instructions for use, to prevent the equipment from overheating or interfering with patient therapy.
- Do not use the equipment outside a temperature of 50°C. Using the equipment outside of this temperature range can compromise the equipment performance which consequently can result in degradation of the health of the patient.
- To prevent disconnection of the tubing or tubing system during use, especially during ambulatory use, only use tubes with a retention force in conformance with ISO 5367 or ISO 80601-2-74.
- To reduce the likelihood of disconnection and to prevent adverse equipment performance use only accessories compatible with the equipment. Compatibility is determined by reviewing the instructions for use of either the equipment or the accessories.
- Use only spare parts recommended by the manufacturer to ensure proper function and to avoid the risk of fire and burns.

- Only water-based lotions or salves that are oxygen-compatible before and during oxygen therapy. Never use petroleum-based or oil-based lotions or salves to avoid the risk of fire and burns.
- Do not add any attachments or accessories to the equipment that contravene the instructions for use of the equipment or accessory, as the equipment might not function correctly leading to the risk of degradation of health of the patient.

The EXHALATION VALVE shall be completely DISCONNECTED while using HFOT mode

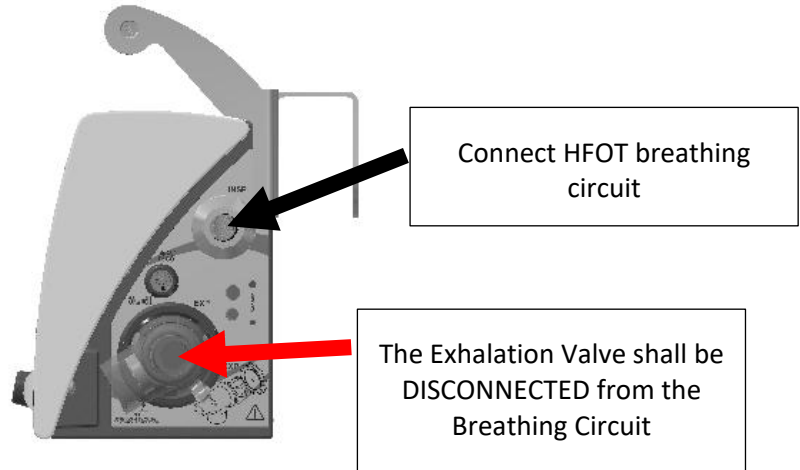

8 Alarms Available

All alarm setting reference is found in the technical specification chapter.

WARNING

- **Alarms and alerts should be promptly addressed in order to maintain the integrity of the operation of the equipment and patient safety.**
- **While the audio volume is set to below the maximum level (5), if there is an alarm, the audio volume will increment gradually every 15 seconds until it reaches its maximum level.**
- **Once ceased the situation that led to pause the audible alarm, you should re-enable it for patient safety.**

8.1 Description of alarm control

The alarm system of the OxyMag family ventilators is classified according to the degree of priority (low, medium, and high priority) as shown in table.

Table 21: Classification of alarms according to the priority level

HIGH PRIORITY	Delay Time	Description
Low Battery	< 1 second	It is triggered when the internal battery is with the charge in the end. Provide appropriate means of ventilatory support to the patient
Apnea	< 1 second	It is triggered when the time elapsed since the last inspiration is greater than the value set for apnea alarm
Low O ₂ Pressure	< 1 second	It is triggered when pressure of oxygen network is insufficient for equipment operation.
Obstruction	< 2 cycles	It is triggered when there is obstruction in the breathing circuit that prevents the complete expiration by the patient
Disconnection	< 5 cycles	It is triggered when there is disconnection of the breathing circuit, which prevents proper ventilation of the patient
High Maximum Pressure	< 2 cycles	It is triggered when the ventilation pressure exceeded the set alarm value as the upper limit of pressure
Low Maximum Pressure	< 2 cycles	It is triggered when the ventilation pressure is below the set alarm value as the lower limit of pressure

HIGH PRIORITY	Delay Time	Description
High Volume	< 3 cycles	It is triggered when the measured volume exceeded the alarm value set as the upper limit of volume
Low Volume	< 3 cycles	It is triggered when the measured volume exceeded the alarm value set as the lower limit of volume
High EtCO ₂	< 3 seconds	It is triggered when the expired CO ₂ has exceeded the alarm value set as the upper limit of EtCO ₂
Low EtCO ₂	< 3 seconds	It is triggered when the expired CO ₂ is below the alarm value set as the lower limit of EtCO ₂
CO _{2i}	< 3 seconds	It is triggered when the inspired CO ₂ has exceeded the alarm value set as the upper limit of CO _{2i}
High FC	< 3 seconds	It is triggered when the heart rate has exceeded the alarm value set as upper limit of FC
Low FC	< 3 seconds	It is triggered when the heart rate is below the alarm value set as lower limit of FC
Low SpO ₂	< 3 seconds	It is triggered when the Oxygen saturation is below the alarm value set as lower limit of SpO ₂
 IRMA Adapter	< 3 seconds	It is triggered when there is one of the conditions: the IRMA adapter of CO ₂ sensor is not connected or must be replaced
Restart IRMA	< 3 seconds	It is triggered when IRMA CO ₂ sensor must be disconnected and re-connected
Change IRMA	< 3 seconds	It is triggered when IRMA CO ₂ sensor must be replaced.
FiO ₂ below 18%	< 3 cycles	It is triggered when FiO ₂ measured is lower than 18%

MEDIUM PRIORITY	Delay Time	Description
High Minute volume	< 3 cycles	It is triggered when the minute volume of the patient has exceeded the alarm value set as upper limit of minute volume
Low Minute volume	< 3 cycles	It is triggered when the minute volume of the patient is below the alarm value set as lower limit of minute volume
High Rate	< 3 cycles	It is triggered when the respiratory rate of the patient has exceeded the alarm value set as upper limit of the respiratory rate
Low Rate	< 3 cycles	It is triggered when the respiratory rate of the patient is below the alarm value set as lower limit of the respiratory rate
High PEEP	< 3 cycles	It is triggered when the pressure in the end of exhalation (PEEP) has exceeded the alarm value set as upper limit of PEEP
Low PEEP	< 3 cycles	It is triggered when the pressure in the end of exhalation (PEEP) is below the alarm value set as lower limit of PEEP
CO ₂ out of range	< 3 seconds	It is triggered when IRMA CO ₂ reading is incorrect
IRMA out of range	< 3 seconds	It is triggered in one of the situations with the CO ₂ sensor: <ul style="list-style-type: none"> • Internal temperature of operation is out of scale or • Ambient pressure of operation is out of scale
IRMA zero required	< 3 seconds	It is triggered when there is need of Zero calibration of IRMA CO ₂ sensor
Hight Temperature	< 3 seconds	It is triggered when the environment condition is above 50°C.
Low Temperature	< 3 seconds	It is triggered when the environment condition is below -18°C.
High FiO ₂	< 3 cycles	It is triggered when the measured FiO ₂ has exceeded the alarm value set as the upper limit of FiO ₂
Low FiO ₂	< 3 cycles	It is triggered when the measured FiO ₂ has exceeded the alarm value set as the lower limit of FiO ₂

LOW PRIORITY	Delay Time	Description
AC input fail	< 1 second	It is triggered when the equipment is disconnected from the electric mains and the power is switched to internal power supply.
 SpO ₂ Sensor	< 3 seconds	It is triggered when SpO ₂ Sensor is connected to the equipment, but is outside the finger
Check SpO ₂	< 3 seconds	It is triggered when: <ul style="list-style-type: none"> • Oximeter has no sensor connected. • Sensor connected is defective • Interference detected • Excessive Ambient light • Sensor unknown
Check cable	< 3 seconds	It is triggered when the cable is disconnected
Low Perfusion	< 3 seconds	It is triggered when there is low perfusion
Looking for pulse	< 3 seconds	It is triggered when oximeter is looking for pulse
SpO ₂ demo	< 3 seconds	It is triggered when the oximeter is generating a demo curve

Note

- When CPAP/PSV mode is configured with pressure support and apnea condition occurs, audible and visual alarm will be triggered; audible alarm will sound only two sequences of high-priority alarms; however, the visual alarm will continue to identify this condition while this exists.
- At temperatures between 40 and 50 °C or between -18 and 0 °C, the capnography sensor may continue to operate, but outside tolerance specifications.

Among the existing alarm conditions, there are alarms with non-adjustable parameters; these have unique characteristics for their activation, which will be described in the following topics.

a) Battery Alarm

This alarm is triggered when the internal battery has a low charge. In this condition, the value of voltage found in the internal battery is below the limit established as essential to the proper operation of the equipment. In this case, an alternative energy source must be provided immediately. The alarm will be re-initialized when connected to a source of A.C. power or external D.C.

Note

- The actual remaining time will depend on the battery condition and parameters used in the ventilator.
-

b) Disconnection alarm

The disconnection alarm is triggered when any kind of disconnection from the breathing circuit occurs, which prevents proper ventilation to the patient. In this case, there are two criteria to check the disconnection. The first criterion is based on the measured values of positive end-expiratory pressure (PEEP). When the airway pressure during exhalation is below the value set for PEEP, the ventilator records the measured values and, when reaching a threshold value, triggers the disconnection alarm. The second criterion for this alarm is based on the measured values for compliance. In this case, the alarm goes off when compliance records a value above the maximum allowed (200 mL/cmH₂O) or does not identify when a variation of natural internal pressure occurs when delivering a certain volume of air to a breathing circuit.

c) Obstruction alarm

The obstruction alarm is triggered when there is some form of obstruction in the breathing circuit preventing full exhalation of the patient. In the **PEDIATRIC** and **ADULT** mode, the criterion to trigger this alarm is based on the ratio of average values from PEEP and pressure limit (P_{max}). When the pressure value is above the average of the reference parameters (PEEP and P_{max}), the alarm is triggered.

In the **NEONATAL** mode, the obstruction alarm is triggered when airway pressure is above the PRESSURE SET + 5cmH₂O. When an occlusion occurs in the breathing circuit, the ventilator triggers a valve system of overpressure that releases the pressure in the circuit in order to preserve the integrity of the patient's lungs.

d) O₂ pressure alarm

The O₂ pressure alarm is triggered when the pressure in the oxygen network is below than 30 psi (207 kPa).

Table 22: Alert Messages

Alert	Delay Time	Description
LIMITED PRESSURE	< 1 second	It is displayed when the monitored pressure reaches the set maximum pressure. In this case, the volume delivered by the ventilator will not reach the set volume
SENSOR OFF	< 3 cycles	It is displayed when the proximal flow sensor is disconnected. In this case, all monitoring depending on this sensor (VT, MV, Rate, Vins, Tinsp, I:E, T exp, Cest, Cdin, Res, τ , iT, Volume Leakage, VxTime Chart) will NOT be provided. In the volume-controlled ventilatory modes, the volume delivered by the equipment will have a variation of up to $\pm 10\%$
Assist. Fl. Trig	< 1 second	It is displayed in the event of an assisted trigger generated by a flow trigger
Assist. Pr. Trig	< 1 second	It is displayed in the event of an assisted trigger generated by a pressure trigger
Assist. Man. Trig	< 1 second	It is displayed in the event of an assisted trigger generated by a Manual trigger
Spont. Fl. Trig	< 1 second	It is displayed in the event of a spontaneous trigger generated by a flow trigger
Spont. Pr. Trig	< 1 second	It is displayed in the event of a spontaneous trigger generated by a pressure trigger
Spont. Man. Trig	< 1 second	It is displayed in the event of a spontaneous trigger generated by a Manual trigger

WARNING

- **The apnea time can be RESET; in this condition, there will be no apnea condition Information and no backup ventilation in action. The equipment operator must be aware of the DEACTIVATED Apnea Alarm condition (INDICATING ON DISPLAY).**
- **The default values of alarms are only for initial reference. Reset the alarm limits as needed by the patient.**
- **Automatic Adjustment of alarm limits set the alarms to a percentage calculated on the value monitored during ventilation; thus, it can only be adjusted when the ventilator is NOT in standby mode.**
- **Do not use the equipment if a problem cannot be resolved.**

Table 23: Troubleshooting

Problem	Possible Causes	Solutions
Ventilator Inoperative Alarm	Electronic failure	Contact Technical Assistance / Magnamed
Disconnection Alarm	1. Disconnection in the breathing circuit;	1. Locate the disconnection and connect securely;

Problem	Possible Causes	Solutions
	2. Lack of Inspiratory Flow;	2. Check if there is inspiratory flow and increase, if necessary;
	3. Change in the Patient's Respiratory Mechanics;	3. Set new parameters for ventilatory support;
	4. Diaphragm of exhalation valve mounted incorrectly or damaged;	4. Replace the diaphragm in the correct position or replace diaphragm with a new one;
	5. Failure in the electronic system of pressure control;	5. Contact Technical Assistance / Magnamed
	6. Circuit integrity	6. Check circuit integrity and replace circuit if necessary
Low Pressure Alarm	1. Change in Patient's Respiratory Mechanics; 2. Excessive leakage in the breathing circuit;	1. Set new parameters for ventilatory support; 2. Locate the leak and correct it;
High Pressure Alarm	1. Change in the Patient's Respiratory Mechanics; 2. Obstruction in the expiratory limb of the breathing circuit or exhalation valve; 3. Obstruction of the airway of the patient;	1. Set new parameters for ventilatory support; 2. Clear it; 3. Clear or aspirate the airway of the patient;
Low Battery Alarm	1. Low charge on the internal battery after prolonged use disconnected from the mains; 2. Failure in the charging system of the internal battery, even with the presence of electric power;	1. Immediately restore the connection of the equipment to a main or turn off the equipment and provide means of ventilatory support to the patient; 2. Contact Technical Assistance / Magnamed;
AC input fail alarm	1. Disconnection to the power cord; 2. Failure in the electrical grid;	1. Restore connection of the equipment to a main or use the equipment with internal battery for transportation; 2. Restore power grid;
Apnea alarm	1. Spontaneous breathing of the patient was interrupted 2. Adjusted apnea time is greater than the patient's respiratory rate.	1. Change the ventilation mode from spontaneous to assisted-controlled. 2. Increase the adjusted apnea time or decrease the patient's respiratory rate.
Low O ₂ Pressure alarm	1. Pressure of the O ₂ supply is low 2. O ₂ hose is not connected to the equipment	1. Increase the O ₂ supply pressure or change the O ₂ cylinder.

Problem	Possible Causes	Solutions
	3. O2 Pressure Sensor Failure	2. Connect the O2 hose to the device. 3. Contact Magnamed Technical Assistance.
Obstruction alarm	1. Inspiratory or expiratory branch obstructed 2. Patient's airway obstruction	1. Clear it. 2. Clear or aspirate the patient's airway.
Low Maximum Pressure alarm	1. Leak in patient circuit 2. Inspiratory pressure lower than set alarm limit	1. Locate the leak and correct. 2. Increase the lower limit of the pressure alarm or increase the set inspiratory pressure.
High Volume alarm	1. Expired volume is greater than the set alarm limit. 2. Flow sensor is out of calibration.	1. Change the parameters set in ventilation mode or set the upper limit of the volume alarm. 2. Perform self-test.
Low Volume alarm	1. Expired volume is less than the set alarm limit. 2. Flow sensor is out of calibration.	1. Change the parameters set in ventilation mode or adjust the lower limit of the volume alarm. 2. Perform self-test.
High FiO ₂ alarm	1. FiO ₂ adjust is above alarm limit 2. O ₂ cell is out of calibration 3. Damaged O ₂ cell.	1. Change the set FiO ₂ or upper alarm limit 2. Calibrate O ₂ cell 3. Contact Magnamed Technical Assistance.
Low FiO ₂ alarm	1. FiO ₂ adjust is below alarm limit 2. O ₂ cell is out of calibration 3. Damaged O ₂ cell.	1. Change the set FiO ₂ or lower alarm limit 2. Calibrate O ₂ cell 3. Contact Magnamed Technical Assistance.
High EtCO ₂ alarm	1. Expired CO ₂ is above alarm limit 2. Capnography sensor is out of calibration 3. Capnography sensor damaged.	1. Change the parameters set in ventilation mode or set the upper limit of the EtCO ₂ alarm. 2. Calibrate capnography sensor. 3. Contact Magnamed Technical Assistance.
Low EtCO ₂ alarm	1. Expired CO ₂ is below alarm limit 2. Capnography sensor is out of calibration 3. Capnography sensor damaged.	1. Change the parameters set in ventilation mode or set the internal limit of the EtCO ₂ alarm. 2. Calibrate capnography sensor. 3. Contact Magnamed Technical Assistance.
CO ₂ i alarm	1. Inspired CO ₂ is above alarm limit	1. Change the parameters set in ventilation mode or set the upper limit of the CO ₂ i alarm.

Problem	Possible Causes	Solutions
High FC alarm	1. Patient heart rate is above alarm limit.	1. Change the parameters set in ventilation mode or set the upper limit of the HR alarm.
Low FC alarm	1. Patient heart rate is below alarm limit.	1. Change the parameters set in ventilation mode or set the lower limit of the HR alarm.
Low SpO ₂ alarm	1. Patient O ₂ saturation is below alarm limit.	1. Change the parameters set in ventilation mode or set the lower limit of SpO ₂ alarm.
 IRMA Adapter alarm	1. The capnograph adapter is not connected. 2. Capnograph adapter failure.	1. Connect the capnograph adapter to the patient circuit. 2. Replace capnograph adapter.
Restart IRMA alarm	1. The capnography sensor is not operating correctly.	1. Disconnect and reconnect the capnography sensor.
Change IRMA alarm	1. The capnography sensor is not operating correctly.	1. Replace capnography sensor.
FiO ₂ below 18% alarm	1. O ₂ concentration delivered to the inner patient at 18%. 2. Unbalanced O ₂ cell. 3. Damaged O ₂ cell.	1. Check the O ₂ net or cylinder. 2. Calibrate O ₂ cell. 3. Contact Magnamed Technical Assistance.
High Minute volume alarm	1. Volume delivered and delivered respiratory rate are above alarm limit.	1. Change the adjusted parameters of the ventilation mode or set the upper limit of the minute volume alarm.
Low Minute volume alarm	1. The delivered volume ratio and respiratory rate are below the alarm limit.	1. Change the adjusted parameters of the ventilation mode or adjust the lower limit of the minute volume alarm.
High Rate alarm	1. Patient's respiratory rate is above alarm limit. 2. Adjusted sensitivity is causing self-triggering.	1. Change the set respiratory rate or change the upper alarm limit. 2. Change the trigger setting.
Low Rate alarm	1. Patient respiratory rate is below alarm limit. 2. Adjusted trigger is too high, and the ventilator does not recognize patient effort.	1. Change the adjusted respiratory rate or change the lower alarm limit. 2. Change the trigger setting.
High PEEP alarm	1. Monitored PEEP is above alarm limit. 2. Obstruction in the patient's breathing circuit.	1. Change the adjusted PEEP or change the upper alarm limit. 2. Clear it.
Low PEEP alarm	1. Monitored PEEP is below alarm limit. 2. Leak in patient circuit.	1. Change the adjusted PEEP or change the lower alarm limit.

Problem	Possible Causes	Solutions
		2. Locate the leak and correct.
CO ₂ out of range alarm	1. Capnograph reading is incorrect.	1. Calibrate or replace the capnograph.
IRMA out of range alarm	1. Operating ambient pressure is out of range 2. The internal operating temperature is out of range.	1. Operate the capnograph under environmental conditions stated in the technical specification. 2. Replace capnography sensor.
IRMA zero required alarm	1. Capnograph has lost calibration	1. Calibrate the capnograph.
High Temperature alarm	1. The ambient temperature is above 50 ° C.	1. Operate the ventilator under environmental conditions stated in the technical specification.
Low Temperature alarm	1. The ambient temperature is below -18 ° C.	1. Operate the ventilator under environmental conditions stated in the technical specification.
 SpO ₂ Sensor alarm	1. The SpO ₂ sensor is connected to the equipment but is off the finger.	1. Connect the oximeter to the patient's finger.
Check SpO ₂ alarm	1. The oximeter has no sensor attached 2. The connected sensor is defective 3. Interference detected 4. Too much of ambient light 5. Unknown sensor.	1. Connect an oximetry sensor. 2. Replace the oximetry sensor. 3. Use the oximeter in an environment without interference. 4. Decrease the ambient light. 5. Replace the oximetry sensor.
Check cable alarm	1. The oximeter cable is disconnected.	1. Connect the oximeter sensor cable.
Low Perfusion alarm	1. The monitored perfusion is below the set alarm limit.	1. Change the ventilation parameters or set the lower limit of the Perfusion alarm.
Looking for pulse alarm	1. The oximeter is looking for pulse	1. Wait for the oximeter to find the patient's pulse.
Activating SpO ₂ alarm	1. The oximeter being activated.	1. Wait for the oximeter to activate.
SpO ₂ demo alarm	1. The oximeter is generating a demonstrative curve.	1. Disconnect and reconnect the oximetry sensor or replace the sensor.

8.2 Setting Alarms

To enter the alarm setting screen, press ALARM button  on the screen. One of the screens of the following table will be presented:

1. Positioning settings of lower and upper limits on the alarm screen:



2. Adjustable alarms of capnography will be visible if the capnography is connected to the ventilator, as well as the adjustable oximetry alarms will be visible when the oximeter is connected.

To change the alarm values just touch the area corresponding to the alarm limit to be set. The parameter touched will be selected indicating that is possible to change; in this case, use the knob button to set the desired value and confirm by pressing this button or by touching again on the parameter adjusted.

8.3 Alarm test

8.3.1 Adjustable alarm test

To perform alarm testing, a breathing circuit and a simulator balloon are required.

Caution

- Never perform alarm testing with the patient connected to the equipment.
-

8.3.1.1 Pressure alarm

To test the high pressure alarm, enter PCV mode, set PEEP to zero, Pr insp to 5 and set the upper limit of the Ppeak alarm to 5. Set up the complete circuit, ventilate and press the test balloon so that the monitored pressure is greater than the set pressure. To test the low pressure alarm, set the lower limit of the pressure alarm so that it is higher than the pressure monitored on the device.

8.3.1.2 PEEP alarm

To test the high PEEP alarm, set the upper PEEP alarm limit so that it is lower than the PEEP monitored on the device. To test the low PEEP alarm, set the lower limit of the PEEP alarm so that it is higher than the PEEP monitored on the device.

8.3.1.3 Minute volume alarm (MV)

To test the operation of the high minute volume alarm, set the upper limit of the minute volume alarm so that it is less than the minute volume monitored on the unit. To test the operation of the low minute volume alarm, set the lower limit of the minute volume alarm so that it is greater than the minute volume monitored on the unit.

8.3.1.4 Respiratory Rate alarm

To test the operation of the high respiratory rate alarm, set the upper limit of the respiratory rate alarm so that it is lower than the monitored respiratory rate on the device. To test the operation of the low respiratory rate alarm, set the lower limit of the respiratory rate alarm so that it is higher than the respiratory rate monitored on the device.

8.3.1.5 Volume alarm

To test the high volume alarm, set the upper limit of the volume alarm so that it is lower than the tidal volume set on the device. To test the low volume alarm, set the lower limit of the volume alarm so that it is higher than the inspiratory volume monitored on the device.

8.3.1.6 FiO2 alarm

To test the high O2 concentration alarm, adjust the maximum concentration in the alarms below the setting in the mode. To test the low O2 concentration alarm, set a minimum concentration in the alarms above the setting in the mode.

8.3.1.7 EtCO2 alarm

To test the EtCO2 alarm, a capnograph must be connected to the ventilator. Assemble the complete circuit for use with a capnograph and blow into the airway adapter for the ventilator to monitor the capnography parameters. To test the high EtCO2 alarm, adjust the EtCO2 upper alarm limit so that it is lower than the EtCO2 monitored on the device. To test the low EtCO2 alarm, adjust the lower limit of the EtCO2 alarm so that it is greater than the EtCO2 monitored on the device.

8.3.1.8 Pulse rate alarm

To test the heart rate alarm, a pulse oximeter must be connected to the ventilator. Mount the circuit and connect the oximeter to your finger so that the ventilator monitors the oximetry parameters. To test the high heart rate alarm, set the upper limit of the heart rate alarm so that it is lower than the heart rate monitored on the device. To test the low heart rate alarm, set the lower limit of the heart rate alarm so that it is higher than the heart rate monitored on the device.

8.3.1.9 CO2 alarm

To test the inspired CO2 alarm, a capnograph must be connected to the ventilator. Assemble the complete circuit for use with a capnograph and blow into the airway adapter for the ventilator to monitor the capnography parameters. Adjust the inspired CO2 alarm so that it is lower than the inspired CO2 monitored on the device.

8.3.1.10 SpO2 alarm

To test the SpO2 alarm, a pulse oximeter must be connected to the ventilator. Assemble the circuit and connect the oximeter to the finger so that the ventilator monitors the oximetry parameters. Set the SpO2 alarm so that it is lower than the SpO2 monitored on the device.

8.3.1.11 Apnea alarm

To test the apnea alarm, set the apnea alarm time to 3 seconds and in ventilation mode, a low respiratory rate. Put the ventilator in normal operation and wait for the time set for the alarm to occur.

8.3.2 Critical alarm test

8.3.2.1 Disconnection

To test the disconnection alarm, select the patient and set the desired modality. Start ventilation and disconnect somewhere in the patient circuit: inspiratory limb, expiratory limb or Y-connector. The high priority disconnection alarm should occur.

8.3.2.2 No AC power

To test the alarm without mains power, put the ventilator in normal operation and disconnect the device from the mains. Low priority mains off alarm shall occur.

8.3.2.3 Low battery

To test the low battery alarm, put the ventilator in normal operation and disconnect the device from the mains and start ventilation. Wait until the battery level reaches a critical level for the low battery, high priority alarm to occur.

8.3.2.4 Obstruction

To test the obstruction alarm, put the ventilator in normal operation and press the expiratory limb of the patient circuit in order to simulate the obstruction and observe the activation of the high priority alarm.

8.3.2.5 Low O2 supply

To test the low O2 pressure alarm, place the ventilator in normal operation, disconnect the oxygen source from the ventilator and observe the activation of the high priority alarm.

8.4 Manual Ventilation of the Patient

To perform manual ventilation to a patient, the ventilator must be on STAND-BY. In this situation, if the flow sensor is connected to the patient's breathing circuit, the monitoring of ventilation will be fully operational, including its alarm system.

WARNING

- ***During a manual ventilation, monitor the maximum pressure***
- ***During a manual ventilation, keep the alarm system active***
- ***Test Sequence must be performed with the patient disconnected***
- ***In case of failure, check the Alarm Control Description***

- *Do not use the equipment if the test fails.*
-

Note

- Use the recommended pressure in the gas inlet.
-

9 Cleaning and Disinfection

9.1 Equipment cleaning

9.1.1 External ventilator surfaces

External ventilator surfaces of OxyMag should be cleaned with a clean, soft cloth moistened with the enzymatic detergent.

Caution

- Ensure that no residue builds up in the equipment connections.
 - For cleaning do not use non-compliant products to polymer
 - For touch screen cleaning avoid:
 - Use substances other than glass cleaner and do not use solutions vinegar base.
 - Use the clean cloths and handle the display carefully.
 - Not to be used for cleaning or disinfecting the phenol (> 5%) ketone, formaldehyde, hypochlorite, chlorinated hydrocarbons, aromatic hydrocarbons, inorganic acids, and quaternary ammonium compounds.
-

10.1.2. Autoclavable respiratory circuit, proximal flow sensor and exhalation valve

The components that come in directly contact with respiratory gases shall be periodically disassembled in components, as accessory list, for cleaning, disinfection or sterilization.

Circuits and parts of silicone should be cleaned according the following steps:

9.1.1.1 Wash

- a) Always use potable water for this procedure;
- b) Use neutral and enzymatic detergent. Dilution should be performed as recommended by the manufacturer.
- c) Immerse the entire body of the flow sensor and the silicone line in the detergent solution, keeping the solution in contact with the accessories for at least 3 minutes;
- d) The external parts of the parts should be cleaned with a clean, soft cloth moistened with the enzymatic detergent. The internal parts must be cleaned by immersion.

9.1.1.2 Rinse

- a) Always use potable water for rinsing;
- b) Thoroughly rinse the external surface of the accessories with potable water.
- c) Rinse the internal surface by injecting potable water under pressure at least 5 times.

Caution

- Not to be used for cleaning or disinfecting the phenol (> 5%) ketone, formaldehyde, hypochlorite, chlorinated hydrocarbons, aromatic hydrocarbons, inorganic acids, and quaternary ammonium compounds.
- Never use saline solutions, especially sodium hypochlorite (bleach) and saline, disinfectants, hydrogen peroxide for cleaning or rinsing the accessories.

9.1.1.3 Drying

Drying of the external parts should be done with a clean, soft and dry cloth and the drying of the internal parts should be done so that the solution drains by gravity.

9.2 Disinfection

9.2.1 External Parts

The external part should be disinfected using a clean cloth moistened with alcohol 70 °.

9.2.2 Autoclavable respiratory circuit, exhalation valve, proximal flow sensor and silicone line

After cleaning, the items should be disinfected with alcohol 70°. The external part should be disinfected using a clean cloth moistened with alcohol 70 ° and internal part by immersion. Important: Do not soak the items to be disinfected with alcohol as it can damage the material.

After disinfection, the external parts should be dried with a clean, soft and dry cloth and the internal parts should be dried so that the solution drains by gravity.

9.3 Sterilization

The components that get in touch with the respiratory gases shall be disassembled in components, as accessory list, for cleaning and sterilization;

Do not use abrasive agents to carry out cleaning;

Do not use alcohol to clean the plastic parts;

Do not immerse the Oxymag in any liquid;

WARNING

- ***When sending the Oxymag for maintenance or repair strictly observe the disinfection process.***
- ***Equipment visibly infected by patients fluid will be returned without performing maintenance or repair service.***
- ***This equipment and the parties must go through a cleaning process every time it is even used in the first use.***

Caution

- The accessories and components removable from Oxymag undergoing repeated operations of sterilization and cleaning may be degraded and should be replaced with new ones.

9.4 Processing methods

Component	Processing methods		
	Steam sterilization 135°C for 5 min	Antimicrobial disinfectant	Alcohol 70°
Ventilator surface	X	✓	X
Touch screen display	X	✓	✓
Silicone respiratory circuit	✓	✓	✓
Silicone sensor line	✓	✓	✓
Exhalation valve	✓	✓	✓
Diaphragm	✓	✓	X
Proximal flow sensor (Adu, Ped and Neo)	✓	✓	✓
SpO2 sensor	X	✓	X
EtCO2 sensor	X	✓	X

Caution

- Do not reuse single use parts and pieces. The reuse of single use accessories may affect the properties of the device and harm the patient.

10 Preventive Maintenance

Caution

- Oxymag should have their maintenance performed only by a qualified technician, trained, and authorized by MAGNAMED. Failure to comply will void the manufacturer's warranty and obligations regarding the ventilator.
 - Failure to perform maintenance could affect the safety and performance of the ventilator.
 - All maintenance shall be done with the patient disconnected from the equipment.
-

10.1 Indication of the need for periodic maintenance

The equipment displays in the home screen the preventive maintenance symbol  when 5000 hours or more had passed since the last maintenance.

10.2 Daily checks and/or prior to use

- Cleaning the equipment.
- Integrity of the power cord of the AC/DC converter.
- Correct operation of the visual and audible alarm system.
- Installation and cleaning of filters.
- Correct display of the screen.
- Correct use of touch screen.
- Full battery.
- Correct operation of the equipment panel keys.
- Correct operation of the knob button.
- Correct installation of the breathing circuit (including the existence of diaphragm of the exhalation valve).

WARNING

- ***Daily check should be performed with the patient disconnected.***
-

10.3 Internal Lithium Battery

This battery is Responsible to power the equipment in the absence of electricity and its duration in normal operation is specified in 15.3.1 Electrical Characteristics.

WARNING

- ***This equipment must ALWAYS remain connected to the mains so that there is sufficient charge during a power outage.***
-

Caution

- The battery must be replaced as indicated in the technical specifications so that capacity in normal operation is as specified.
 - Replacement of internal battery should be performed only by a qualified technician, trained, and authorized by MAGNAMED.
 - Battery should always be checked in periodic maintenance.
-

10.4 Internal Sensor of O₂ Concentration

The oxygen concentration sensor is a cell that generates electrical signal proportional to the oxygen concentration in the gas mixture administered to the patient and the intensity of this electrical signal is due to the chemical reaction. The length of the cell, as specified by the original manufacturer is 10,000 hours at 100% O₂, i.e., more than one year of continuous use.

Caution

- The galvanic O₂ cell undergoes less than 1% per month degradation in measurement accuracy.
 - The oxygen concentration measuring cell should be replaced as indicated in the Technical Specification (chapter 14).
 - Replacement of the oxygen concentration measuring cell should be performed only by a qualified technician, trained, and authorized by MAGNAMED.
-

10.5 Replacing the Ambient Air Filter

To replace the ambient air filter, follow the procedure below:

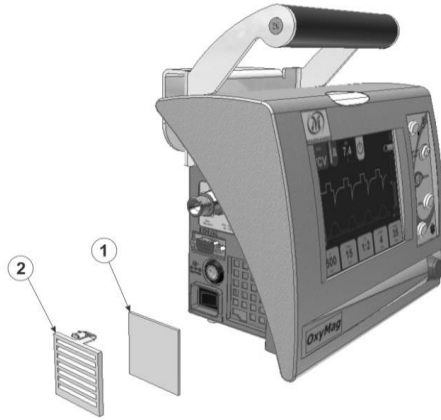

Figure 28: Example for exchanging air filter

- (1) Remove the filter cover on the left side of the ventilator, item 2 of the figure.
- (2) Remove the old filter, item 1 of the figure.
- (3) Clean the seating area of the filter with a cotton ball soaked in water and mild soap solution.

Caution

- Do not use compressed air for cleaning, as this may introduce dust and dirt in the gas mixing system.

- (4) After drying, introduce a new filter.
- (5) Install the filter cover and check if the set is firmly closed.

WARNING

- **Use only filters, parts, pieces and accessories specified by MAGNAMED listed in this manual, which have been tested and approved for use in conjunction with this equipment; otherwise, this can jeopardize the operation endangering the patient or user.**
- **Filter when saturated generates an increase in the resistance of the ambient air inflow and can make the minimum concentrations (35% O₂) to not be met. In this case, replace the filter.**

Caution

- Do not operate the equipment without this filter, because it may damage the system controlling the air/oxygen mixture.

10.6 Forwarding the Product to Repair Service

Products before being sent for repair service should be cleaned and disinfected as directed in this manual Cleaning and Disinfection (chapter 10). Products showing signs of potential hospital contaminants will be returned without repair service in order to be disinfected prior to the service.

WARNING

- *When sending Oxymag for maintenance or repair services: check and closely follow the disinfection process.*
 - *Equipment visibly infected by patient fluids will be returned without carrying out maintenance or repair service.*
-

11 Disposal

Oxymag ventilator shall be disposed of as electrical and electronic equipment. Accessories and consumables shall be disposed of as described in their instruction for use. Follow local government recommendations for proper disposal.

Caution

- When the need to discard parts of the ventilator that may be potentially contaminated indicate it as potentially infected hospital waste.
 - Disposal of batteries shall comply with local regulations.
 - Disposal of galvanic cells shall comply with local regulations.
 - Airway adapters shall be disposed of in accordance with local regulations for medical disposal.
-

12 Turning off the Equipment

The lung ventilator OxyMag is a life support equipment and must be MANDATORILY disconnected from the patient to be turned off. The equipment should be turned off in the on/off switch, identified in Figure 5. When the equipment is turned off, a continuous audio signal will be produced indicating that the equipment has been turned off. Finally, press via knob button, identified in Figure 1.

13 Technical Specification

13.1 Classification

- NBR – IEC – 60601

Class II Equipment, energized internally, BF-type for continuous operation. Protected against the ingress of solid foreign objects > 2.5 mm or bigger and splash-proof equipment - IP34.

- RDC 751/22 – Classification rule 12

Class III - All active medical devices intended to administer to or remove from the human body medicines, bodily fluids or other substances are classified in class II, unless this is carried out in a potentially hazardous manner, taking into account the nature of the substances or of the part of the body involved and the method of application, in which case they are classified in class III.

13.2 Standards

- **ISO 5356-1** – Anesthetic and respiratory equipment – Conical connectors – Part1: Cones and sockets
- **ABNT NBR 11906** – Conexões roscadas e de engate rápido para postos de utilização dos sistemas centralizados de gases de uso medicinal sob baixa pressão
- **IEC 60601-1 Ed. 3.0 (2005) + Amd. 1 (2012) (EN 60601-1:2006 + A1: 2013)** - Medical electrical equipment - Part 1: General requirements for basic safety and essential performance
- **ISO 5359:2008/Amd 1:2011 (EN ISO 5359:2008+A1:2011)** - Low-pressure hose assemblies for use with medical gases
- **IEC 60601-1-2 (2014) (EN 60601-1-2:2015)** - Medical electrical equipment - Part 1-2: General requirements for basic safety and essential performance - Collateral standard: Electromagnetic compatibility - Requirements and tests
- **IEC 62304:2006 +AMD1:2015 (EN 62304:2006/2008)** - Medical device software - Software life cycle processes
- **IEC 60601-1-8:2006+AMD1:2012+AMD2:2020 (EN IEC 60601-1-8:2006+AMD1:2012+AMD2:2020)** - Medical electrical equipment - Part 1-8: General requirements for basic safety and essential performance - Collateral Standard: General requirements, tests and guidance for alarm systems in medical electrical equipment and medical electrical systems
- **IEC 60601-1-4: 1996/A1:1999 (EN 60601-1-4: 1996/A1: 1999)** - Medical electrical equipment - Part 1-4: General requirements for safety - Collateral standard: Programmable electrical medical systems
- **IEC 60601-1-6:2010+A1:2013+A2:2020 (EN 60601-1-6:2010+A1:2013+A2:2020)** - Medical electrical equipment - Part 1-6: General requirements for basic safety and essential performance - Collateral standard: Usability
- **IEC 60601-1-9:2007+AMD1:2013+AMD2:2020 (EN 60601-1-9:2007+AMD1:2013)** - Medical electrical equipment - Part 1-9: General requirements for basic safety and essential performance - Collateral Standard: Requirements for environmentally conscious design
- **IEC 62366:2007 (EN 62366:2008)** - Medical devices - Application of usability engineering to medical devices

- **EN ISO 17665-1:2006** - Sterilization of health care products - Moist heat - Part 1: Requirements for the development, validation and routine control of a sterilization process for medical devices
- **EN ISO 17664:2004** - Sterilization of medical devices - Information to be provided by the manufacturer for the processing of resterilizable medical devices
- **EN 1041:2008** - Information supplied by the manufacturer of medical devices
- **ISO 15223-1:2016 (EN ISO 15223-1:2016)** - Medical devices - Symbols to be used with medical device labels, labelling and information to be supplied - Part 1: General requirements
- **ISO 80601-2-61:2011 (EN ISO 80601-2-61:2011)** – Medical electrical equipment: Particular requirements for basic safety and essential performance of pulse ox equipment
- **ISO 80601-2-55:2018 (EN 80601-2-55: 2018)** - Medical electrical equipment -- Part 2-55: Particular requirements for the basic safety and essential performance of respiratory gas monitors
- **IEC 60601-1-12:2014+A1:2020** - Medical electrical equipment - Part 1-12: General requirements for basic safety and essential performance - Collateral standard: Requirements for medical electrical equipment and medical electrical systems intended for use in the emergency medical services environment
- **ISO 80601-2-84:2020** – Medical electrical equipment – Part 2-84: Particular requirements for the basic safety and essential performance of ventilators for the emergency medical services environment
- **RTCA DO-160G:2010** - Environmental Conditions and Test Procedures for Airborne Equipment⁽¹⁾

(1) Tests of the following items of RTCA DO-160G:

Section	Description	Category
8	Vibration in fixed-wing aircraft	S
	Vibration in helicopters	U
16.6	Voltage fluctuations, voltage ripple	A
17	Voltage spikes	A
18.3.1	Audio frequency susceptibility, DC power input	B
20	Susceptibility to radiofrequency (irradiated and conducted)	R
21	Emission of radio frequency energy	M
25	Electrostatic Discharge (ESD)	A

13.3 Specifications

The transport electronic lung ventilator consists of the following components:

- 320 x 240 points color Liquid Crystal DISPLAY LCD 5.7" graphic with touch screen
- Control Board with:
 - Data presentation on the display
 - Serial interface RS-232C for software update
 - Remote Diagnostics and Remote Assistance Magnamed (ARM)

- Quick access keys for:
 - ✓ HOLD
 - ✓ O₂ 100%
 - ✓ FREEZE
 - ✓ MANUAL (Manual Trigger of Inspiratory Cycle)
 - ✓ LOCK (Lock keys)

- Pressure Reading in the breathing circuit
- Regulated pressure reading
- Smart battery charger

- Speaker for alarms and alerts
- High brightness RED LED for quick Identification of alarms
- GREEN LED indicator of connection to the electrical grid
- Connection to AC/DC External Source (100-240 VAC – 50 – 60 Hz → +12 VDC)
- On/off switch
- Adult breathing Circuit
- Pediatric and Neonatal breathing circuit, optional
- Disposable breathing circuit adult/ pediatric/ neonatal, optional
- Galvanic cell internal O₂
- External source AC/DC converter AC/DC 100 – 240 VAC to +12 VDC;
- Plastic Cabinet in high impact ABS resistant to blows
- Carrying Case with Oxygen Cylinder, optional.
- Carrying Case without Oxygen Cylinder, optional.
- Pedestal for OxyMag, optional.
- Kit blender, optional.
- PEEP valve integrated in the equipment.
- Automatic barometric pressure compensation
- Protection fuses for fixation support and pedestal: Voltage 250V; Current 3A; Operating speed: Medium; Breaking Capacity 100 A, Size: 5mm x 20mm, Quantity: 2.

13.3.1 Electrical Characteristics

Table 24: AC/DC Converter Source – External (2402568 – POWER SUPPLY 12V WITH 4-WAY CONNECTOR)

Item	Parameter	Specification	Tolerance	Unit
1	Mains (50/60Hz)	100 – 240	± 10%	V _{AC}
2	Maximum Power Consumed	40	± 10%	W
3	Output 12V _{DC} – 4 -way	12	± 10%	V _{DC}

Item	Parameter	Specification	Tolerance	Unit
4	Current	3.34	---	A
5	AC Cable	Equipment side connector: As per IEC 60320 type C13 Plug: As per local legislation. Electrical requirements: Compatible with the electrical supply specifications of each device (Voltage and Current). Confirm the marking of the equipment.		

Table 25: Internal Li-Ion Battery

Item	Parameter	Specification	Tolerance	Unit	
1	Internal Li-Ion Battery 11.8V _{DC}	5200	± 15%	mAh	
2	Autonomy of Internal Battery (with full load and normal use) ⁽²⁾	480	± 15%	Min	
3	Time to recharge to full load (module standby) ⁽¹⁾	5.0	± 15%	H	
4	Dimensions	Height	37.8	---	mm
		Width	72.4	---	mm
		Length	56	---	mm
5	Number of charge cycles	500	---	cycle	

⁽¹⁾ The battery should be charged at room temperature, 5 - 35 °C

⁽²⁾ Usage condition:

Adult patient, Volume 500 mL, R. Rate 10 min⁻¹, I:E: 1:2, PEEP 10 cmH₂O, Resis 5 hps(l/s)⁻¹, Compl. 50 ml hPa⁻¹, O₂ 60%

Pediatric patient, Volume 150 mL, R. Rate 20 min⁻¹, I:E: 1:2, PEEP 10 cmH₂O, Resis 20 hps(l/s)⁻¹, Compl. 20 ml hPa⁻¹, O₂ 60%

Neonatal patient, Volume 50 mL, R. Rate 30 min⁻¹, I:E: 1:2, PEEP 10 cmH₂O, Resis 50 hps(l/s)⁻¹, Compl. 1 ml hPa⁻¹, O₂ 60%

- Electromagnetic Compatibility:
 - Immunity: IEC 60601-1-2
 - Emission: CISPR11
 - Approvals: OS/IEC 60601-1
- Protection Class of Breathing Accessories (Disposable or Reusable): BF type  (Body Floating).

13.3.2 Connecting to the Oxygen Supply

- (1) Oxygen Inlet –DISS male thread 9/16” 18 wires, as per ISO 5359
 - OPTIONAL –NIST Thread

- Gas pressure: 39 - 87 psi (270 - 600 kPa) ⁽²⁾
- Hoses and Extensions: As per EN ISO 5359
- The aluminum cylinder for oxygen (1.7 LITERS) has autonomy of 40 minutes with the equipment configuration as follows:
 - o Adult patient
 - o VCV mode
 - o Volume 500ml
 - o Rate 12rpm
 - o Ratio 1:2
 - o PEEP 5 cmH2O;
 - o Pause 30%;
 - o FiO2 100%;
 - o Square flow wave.

Note

- All materials composing the product are compatible with Oxygen, Air and Medicinal Compressed Air.

13.3.3 Physical and Environmental Specifications

Table 26: Physical and environmental specifications

Item	Parameter	Specification	Tolerance	Unit	
1	Dimensions (basic unit)	Height (with handle)	176 (231)	± 2	mm
		Width	254	± 2	mm
		Depth (with handle)	134 (185)	± 2	mm
2	Weight	3.25	± 0,1	kg	
3	Operation	Temperature	-18 - 50	---	°C
		Barometric Pressure	600 - 1100	---	hPa
		Relative Humidity (w/o condensation)	15 - 95	---	%
4	Storage/ Transport	Temperature	-25 - 75	---	°C
		Barometric Pressure	500 - 1200	---	hPa
		Relative Humidity (w/o condensation)	5 - 95	---	%
5	Oxygen consumption in the conditions: <ul style="list-style-type: none"> • Tidal Volume = 500 mL 	92	± 10%	min/L _{O2} -CYLINDER	

² For input pressure to 39 psi (270 kPa), the maximum flow is 100 L / min

Item	Parameter	Specification	Tolerance	Unit
	<ul style="list-style-type: none"> R. Rate = 12 min⁻¹ FiO₂ = 40% 			
6	Lifetime (useful life)	10	---	years
7	Time to heat or cool equipment stored at extreme temperatures to operate at 20 ° C	30	---	minutes
8	Final sound pressure level	45,14	---	dBA
9	Sound power level	51,73	---	dBA

13.3.4 Internal volume of respiratory circuit components

INTERNAL VOLUME	
SILICONE RESPIRATORY TUBE 22M+22M X 1,20M AUTOCLAVABLE	407,8 mL
Y ADULT 22MM AUTOCLAVABLE WITH THERMOMETER	18,7 mL
SILICONE RESPIRATORY TUBE 15MM X 1,20 M AUTOCLAVABLE 15F+22F	179,5 mL
INTERMEDIARY 15M+15M FOR PEDIATRIC BREATHING CIRCUIT AUTOCLAVABLE	3,6 mL
Y PEDIATRIC 15MM AUTOCLAVABLE WITHOUT THERMOMETER 90	16,9 mL
AIRWAY ADAPTER	9,0 mL
ADULT FLOW SENSOR - AUTOCLAVABLE	8,4 mL
PEDIATRIC FLOW SENSOR - AUTOCLAVABLE	8,0 mL
NEONATAL FLOW SENSOR - AUTOCLAVABLE	7,7 mL

13.3.5 Extreme conditions

WARNING

- **Do not store the ventilator in environments outside the temperature, humidity and pressure specified in 13.3.3 Physical and Environmental Specifications. Accuracy of equipment readings may be affected.**
- **AC mains power supply with voltage values below 25% may result in switching power to the internal battery.**
- **Power above 15% of the rated value may result in equipment AC / DC power failure, but the equipment will continue to operate normally due to switching to the internal battery.**

- **AC mains supply with frequency values 5% below or 5% above nominal may result in switching to the internal battery, but the equipment will maintain its normal operation.**

Caution

- The temperature alarm will be triggered if the environmental condition is below -10°C or above 50°C (low/high temperature alarm – medium priority).

13.3.6 Ventilation Modes

Table 27: Ventilation modes

Modes ⁽¹⁾⁽²⁾⁽³⁾	Description	Mode in Apnea (BACKUP) ⁽⁴⁾
VCV ⁽¹⁾⁽²⁾⁽³⁾	Volume-Controlled Ventilation	AUTO
PCV ⁽¹⁾⁽²⁾⁽³⁾	Pressure-Controlled Ventilation	AUTO
PLV ⁽¹⁾⁽²⁾⁽³⁾	Pressure Limited Ventilation Cycled by Time for ventilator in neonatal setting (may have assisted cycles)	AUTO
V-SIMV + PS ⁽¹⁾⁽²⁾⁽³⁾	Volume Controlled Synchronized Intermittent Mandatory Ventilation with Pressure Support	IMV – Volume Controlled Intermittent Mandatory Ventilation
P-SIMV + PS ⁽¹⁾⁽²⁾⁽³⁾	Pressure Controlled Synchronized Intermittent Mandatory Ventilation with Pressure Support	IMV – Pressure Controlled Intermittent Mandatory Ventilation
DualPAP ^{(1)(2)(3) (5)}	Bi-level Positive Airway Continuous pressure with Pressure Support	VCV, PCV (adult and pediatric) / PLV (neonatal), OFF. Programmable by the Operator
CPAP/PSV ⁽¹⁾⁽²⁾⁽³⁾	Continuous Positive Airway Pressure Ventilation with Pressure Support	VCV, PCV (adult and pediatric) / PLV (neonatal), OFF. Programmable by the Operator
CPR ⁽⁶⁾	Cardiopulmonary Resuscitation	--
HFOT ⁽⁶⁾	High Flow Oxygen Therapy	--

⁽¹⁾ Non-Invasive Ventilation by Mask can be activated in all ventilation modes, and, in this case, there is compensation for leaks.

⁽²⁾ Automatic compensation of compliance and small leaks in the breathing circuit.

⁽³⁾ When the ventilator enters in Neonatal mode (IBW ≤ 6.0 Kg) only PLV, P-SIMV, CPAP/ PSV, DualPAP modes will be available

⁽⁴⁾ For the modes where backup ventilator is defined as "Auto", always when the set apnea time is reached, the ventilator starts one ventilator cycle, witch configuration is based on current ventilator mode.

⁽⁵⁾ APRV (Airway Pressure Release Ventilation) mode can be obtained by DualPAP mode with appropriate adjustment of the times and pressures.

⑥ CPR and HFOT modalities are available as options for adult and pediatric patients and unavailable for neonatal patient

13.3.7 Setting Specifications of the Ventilation Parameters

Table 28: Setting specifications of parameters.

Item	Parameter	Specification	Resolution	Unit
1	Tidal Volume	20 to 2500	100 to 2500: 10	mL
			20 to 100: 5	
2	Respiratory rate	0 to 150 ⁽²⁾	1	min ⁻¹
3	Rise time	0 to 2,0	0,1	s
4	Pause	0 to 70	10	%
5	Maximum Limit Pressure	5 to 60	1	cmH ₂ O
6	Inspiratory Pressure	5 to 60	1	cmH ₂ O
7	Delta of support pressure (Δ PS)	OFF; 5 to 60	1	cmH ₂ O
8	PEEP	0 to 40	1	cmH ₂ O
9	Assisted Sensitivity (Pressure)	OFF; -0,2 to -10	-0,2 to -2,0:- 0,2	cmH ₂ O
			-2 to -10:- 1	
10	Assisted Sensitivity (Flow)	OFF; 0,5 to 30,0	0,5	L.min ⁻¹
11	Automatic Inspiratory Flow ⁽³⁾	0 to 150	1	L.min ⁻¹
12	Inspiratory Flow (Neonatal)	4 to 20	1	L.min ⁻¹
13	Cycling by Flow at Pressure Support	5 to 80	5	%
14	O ₂ Concentration	35 to 100	1	%
		21 to 100 (with blender)	1	%
15	Inspiratory Time	0,1 to 10	0,1 to 0,7:0,01	s
			0,7 to 1:0,05	
			1 to 10:0,1	
16	Inspiratory Flow Waveform	Square, Decelerated, Accelerated, Sine	---	---

Item	Parameter	Specification	Resolution	Unit
17	CPAP ⁽⁴⁾	1 to 40	1	cmH ₂ O
18	High Pressure	5 to 55	1	cmH ₂ O
19	Low Pressure	0 to 40	1	cmH ₂ O
20	High Time	0,20 to 60,0	0,20 to 0,70:0,01	s
			0,70 to 1,00:0,05	
			1,00 to 10,0:0,10	
			10,00 to 60,0:1,0	
21	Low Time	0,20 to 60,0	0,20 to 0,70:0,01	s
			0,70 to 1,00:0,05	
			1,00 to 10,0:0,10	
			10,00 to 60,0:1,0	
22	Ratio	1:4 to 4:1 ⁽⁵⁾	1:0,1	-
23	Backup	OFF; PLV; PCV; VCV ⁽⁶⁾	---	-
24	Time for Apnea Alarm	OFF; 5 to 60	1	s
25	Flow (flow meter)	0 to 15	1	L.min ⁻¹
26	Leak Flow Compensation ⁽⁷⁾⁽⁸⁾	Neonatal: 12 L.min ⁻¹ Pediátrico/ Adulto: 100 L.min ⁻¹	1	L.min ⁻¹
27	Height ⁽⁹⁾	0,16 a 2,50	0,16 to 0,52:0,01	m
			0,53 to 1,08:0,01	
			1,09 to 2,50:0,01	

⁽¹⁾ Tidal Volume for values lower than 20ml is set adjusting pressure, monitoring the tidal volume in the display of the ventilator. This volume is the volume delivered to the ventilator outlet, and the user should check the absence of leaks*.

⁽²⁾ In CPAP/PSV mode adjusted without pressure support and without backup respiratory rate will be zero.

⁽³⁾ Inspiratory flow automatically obtained adjusting Volume, Rate, Ratio I:E / Inspiratory time and Pause

Example (1): Volume = 70 mL; Rate = 20 min⁻¹; Ratio= 1:2; Pause = 30%

$$70 \times 20 \times (1+1/0.5)$$

Inspiratory Flow = ----- = 6.00 L/min

$$1000 \times (1-30/100)$$

Example (2): Volume = 2000 mL; Rate = 12 min⁻¹; Ratio 1:2; Pause = 30%

$$2000 \times 12 \times (1+1/0.5)$$

Inspiratory Flow = ----- = 102.86 L/min

$$1000 \times (1-30/100)$$

Example (3): Volume = 2200 mL; Rate = 12 min⁻¹; Ratio 1:3; Pause = 40%

$$2200 \times 12 \times (1+1/0.333)$$

Inspiratory Flow = ----- = 176.00 L/min

$$1000 \times (1-40/100)$$

⁽⁴⁾ In CPAP/PSV mode, if pressure support (Δ PS = zero or Pressure and Flow Sensitivity = zero) is disabled, CPAP parameter will

be adjusted. In CPAP/PSV mode, disabling pressure support (Δ PS equal to zero or Pressure Sensitivity and Flow equal to zero) will adjust the CPAP parameter. Setting the CPAP/PEEP and DeltaPS parameters in CPAP/PSV mode can achieve pressure control from 1 to 60 cmH₂O.

⁽⁵⁾ In VCV, adjustment allowed is in the range between 1:4 and 4:1

⁽⁶⁾ Backup options for CPAP/PSV mode; for DUALPAP mode, backup options are: PLV for neonatal, PCV for adult or OFF. Setting OFF, mode will not enter in backup when time for apnea alarm is reached.

⁽⁷⁾ For modes with controlled volume, maximum compensation is 100% flow adjusted automatically

⁽⁸⁾ For invasive and non-invasive modes

⁽⁹⁾ Depending on the type of patient set during startup, the ventilator will be set to operate according to the following table:

(Patients smaller than 0.16m or greater than 2.5m can be ventilated in this equipment)

Table 29: Ratio Mode x type of patient

Patient Type	Flow Sensor ⁽¹⁾	Initial Mode	Ideal Weight (IBW)	Height [m]
NEONATAL	NEO	PLV	2,8Kg	0,36
PEDIATRIC	INF	PCV	19,8Kg	0,95
ADULT	ADU	VCV	49,5Kg	1,50

The ideal weight is calculated using BMI = 22 and patient height can be changed according to the type of patient set at startup as table below:

Table 30: Calculation of ideal weight x patient height

Patient Type	Height Adjustment [m]		Ideal Weight P [Kg]
	Min.	Max.	
NEONATAL	0,16	0,52	≤ 6,0
PEDIATRIC	0,53	1,08	6,0 < P ≤ 25
ADULT	1,09	2,5	> 25

Caution

- Minimum Limit Pressure: 5 cmH₂O
- Adjusted Maximum Pressure serves to limit the pressure in the breathing circuit.

- On VCV this will be the pressure limit, exhalation valve opens to the environment to maintain this maximum during the inspiratory cycle, exceeding this limit by 5 cmH₂O, the ventilator cycles to the expiratory phase (pressure cycling).
- On PCV this will be the pressure control limit.
- This ventilator DOES NOT GENERATE NEGATIVE PRESSURE IN THE EXPIRATION OF THE PATIENT.
- For the calculation of ventilation parameters, the patient ideal weight obtained according to height is used. Therefore, there is no indication of specific body mass for the use of the product.

13.3.8 Specifications of the Monitoring Ventilation Parameters

Table 31: Ventilation parameters

Item	Parameter	Range	Resolution	Accuracy	Unit
1	Instant Pressure Measured	-20 to 100	1	± (2 cmH ₂ O + 4% of reading)	cmH ₂ O ⁽²⁾
2	Maximum Inspiratory Pressure	0 to 90	1	± (2 cmH ₂ O + 4% of reading)	cmH ₂ O
3	Measured Pressure	0 to 90	1	± (2 cmH ₂ O + 4% of reading I)	cmH ₂ O
4	Plateau Pressure	0 to 90	1	± (2 cmH ₂ O + 4% of reading)	cmH ₂ O
5	PEEP - Pressure at the end of expiration ⁽¹²⁾	-20 to 90	1	± (2 cmH ₂ O + 4% of reading)	cmH ₂ O
6	Intrinsic PEEP at the end of expiration ⁽¹²⁾	-20 to 90	0,1	± (2 cmH ₂ O + 4% of reading)	cmH ₂ O
7	Flow Measured (Sensor Adult) ⁽⁹⁾	-150 to 150	1	± (50mL/min + 10 % of reading)	L.min ⁻¹
8	Flow Measured (Sensor Pediatric) ⁽⁹⁾	-50 to 50	0,5	± (50mL/min + 10 % of reading)	L.min ⁻¹
9	Flow Measured (Sensor Neonatal) ⁽⁹⁾	-20 to 20	0,2	± (50mL/min + 10 % of reading)	L.min ⁻¹
10	Volume Measured (Sensor Adult – ADU) ^{(3) (9)}	100 to 3000	100 to 995:5	± (4,0 mL + 15% of reading)	mL
			1000 to 3000:10	± (4,0 mL + 15% of reading)	

Item	Parameter	Range	Resolution	Accuracy	Unit
11	Volume Measured (Sensor Pediatric – INF) ^{(3) (9)}	10 to 400	2	± (4,0 mL + 15% of reading)	mL
12	Volume Measured (Sensor Neonatal – NEO) ^{(3) (9)}	0 to 100	1	± (4,0 mL + 15% of reading)	mL
13	Minute volume (Sensor Adult – ADU) ⁽⁹⁾	0,0 to 99,0	0,001	± (4,0 mL + 15% of reading)	L
14	Minute volume (Sensor Pediatric – PED) ⁽⁹⁾	0,00 to 50,0	0,001	± (4,0 mL + 15% of reading)	L
15	Minute volume (Sensor Neonatal – NEO) ⁽⁹⁾	0,000 to 20,0	0,001	± (4,0 mL + 15% of reading)	L
16	Tidal Volume Inspired ⁽³⁾	0 to 3000	0 to 1000: 1	± (4,0 mL + 15% of reading)	mL
			1000 to 3000:10		
18	Inspiratory Time	0,05 to 60,0	0,01	± (0,10 s + 10% of reading)	s
19	Expiratory Time	0,05 to 60,0	0,01	± (0,10 s + 10% of reading)	s
20	Ratio I:E	1:100,0 to 100,0:1	1:0,1	± (0,1 + 10 % do of reading)	---
21	Respiratory Rate	0 to 200	1	± (1bpm + 10% of reading)	min ⁻¹
22	Airway Resistance – R _{AW}	0 to 200	1	± (5cmH2O/L/s +20% of reading)	cmH2O/L/s
23	Dynamic Compliance (C.Dyn)	0 to 200	0,1	± (1mL/cmH2O + 10% of reading)	mL.cmH2O ⁻¹
24	Static Compliance (C.Stat)	0 to 200	0,1	± (1mL/cmH2O + 10% of reading)	mL.cmH2O ⁻¹
25	FiO ₂ (Oxygen Concentration)	12 to 110	0,1	± (2,5% + 2,5% of reading)	%O ₂
26	Flow (flowmeter)	0 to 60	0,1	± (0,5mL.min ⁻¹ + 10% of reading)	L.min ⁻¹
27	Regulated Pressure	0 to 150	1	± (3,75 psi + 10% of reading)	psi
28	Oxygen Consumption (Cos. O ₂)	0 to 160	0,1	± (50mL/min + 10% of reading)	L/min

Item	Parameter	Range	Resolution	Accuracy	Unit
29	SpO ₂ ⁽¹⁰⁾ (LNCS DC-I and LNCS YI)	70 to 100	1	± (2% no motion) ± (3% motion)	%
				± 2% (low perfusion)	
30	FC ⁽¹¹⁾ (LNCS DC-I and LNCS YI)	0 to 240	1	± (3 bpm no motion) ± (5 bpm motion)	bpm
				± 3 bpm (low perfusion))	
31	CO ₂ ⁽⁸⁾	0 to 25	0 to 15:1	±(0,2% volume + 2% of reading)	%vol
			15 to 25: Not Specified	Not Specified	

- (1) When indicated two tolerances, consider the highest value.
- (2) 1 mbar (millibar) = 1 hPa (hectoPascal) = 1.016 cmH₂O (centimeter of water). In practice, these units are not differentiated and can be used as:
1 mbar = 1 hPa ≈ 1 cmH₂O
- (3) For airway resistance exceeding 150 cmH₂O/L/s expiratory volume monitored will have tolerance changed to ± 10%. In this condition, the inspired volume measured remains unchanged.
- (4) Tolerance calculated for frequency of 12, 20 and 30 rpm, respectively, for adult, pediatric and neonatal sensors. Tolerance is a function of the uncertainty of volume multiplied by frequency.
- (5) 700 hPa corresponds to an altitude of 3048m
- (6) All monitoring data are considered at ATPD (Ambient, Temperature and Pressure Dry).
- (7) The Ventilator does not generate negative pressure during expiratory phase.
- (8) CO₂(mmHg)=CO₂(%) x Patm(mmHg)x 0.75
- (9) Volume, flow specifications associated with the ventilator respiratory system are expressed in BTPS with 50% oxygen concentration.
- (10) Since pulse oximetry equipment measurements are statistically distributed, it can be expected that only about 2/3 of pulse oximetry equipment measurements will be within ± Arms of the value measured by a co-oximeter.
- (11) Masimo SET technology with Masimo sensors has been validated for heart rate accuracy in the 25-240 bpm range on bench tests with a Biotek Index 2™ simulator. This variation is equal to ± 1 standard deviation. ± 1 standard deviation covers 68% of the population.
- (12) The total PEEP is displayed on the bar graph during the expiratory pause, obtained by summing PEEP and iPEEP.

WARNING

- **Ventilation with cyclic pressure up to 100 cmH₂O can add up to 2% tolerance error.**
- **Parameter accuracy may be affected under the following conditions:**
 - **Reuse of single use accessories**
 - **Incorrect sensor usage for patient type**
 - **Secretion in the circuit and flow sensor**
 - **Uncalibrated oxygen cell and flow sensor**
 - **Condensation in circuit, flow sensor and gas inlet**
 - **Use of nebulizer with capnography sensor**
 - **Proximal flow sensor with tubes facing down.**
- **To maintain ventilator accuracy, keep the flow sensor, breathing circuit, and gas inlet dry, clean, and free of condensation.**

13.3.9 Control accuracy

The following table shows the maximum error between the set value and the value applied by the ventilator.

Table 32 – Parameters accuracy

Item	Parameter	Accuracy ⁽¹⁾
1	Volume delivered (all range)	± (4 mL + 15% of adjusted volume)
2	Inspiratory pressure	± (2 cmH2O + 4% of adjusted pressure)
3	PEEP	± (2 cmH2O + 4% of adjusted PEEP)

⁽¹⁾ Volume and pressure accuracy is preserved for circuits with resistance up to 1.9 cmH2O with 15 LPM flow and compliance up to 5 mL / cmH2O.

The accuracy of the parameters remains independent of oxygen concentration.

Performance accuracies were determined using a test system with the measurement uncertainties described in the table below:

Table 33 – Parameter Uncertainty

Item	Parameter	Uncertainty
1	Volume delivered	± 2,5%
2	Inspiratory pressure	± 2,0%
3	PEEP	± 2,0%

13.3.10 Specifications of the Safety and Alarm System

- Anti-asphyxia valve for fault protection in gas supply
- Safety Release Valve 100 cmH2O – Basic standard of ventilators to avoid overpressure in the breathing circuit
- Overpressure Valve ACTIVE – when detecting obstructions, it is activated to reduce pressure in the patient circuit.

WARNING

- ***When the ventilator is restarted or the type of patient is changed, alarms will assume the default values in Table 36 according to the type of patient. It is not possible to change the default alarm settings permanently***

- **Default values of the alarms are only for initial reference. Reset the alarm limits as needed by the patient.**
- **Apnea Time can be RESET; in this condition, there will be no information of the apnea condition and no backup ventilation in action. The equipment operator must be aware of the DEACTIVATED condition of the Apnea Alarm (INDICATING ON THE DISPLAY).**
- **Automatic adjustment of the alarm limits (table 36) sets the alarms for a percentage calculated on the value monitored during ventilation; therefore, it can only be adjusted when the ventilator is NOT in STANDBY-BY mode.**

The priority of the alarm condition is determined by the risk management process of the equipment and follows the description in Table 34.

Table 34: Priority of the alarm condition

Potential result of a failure to respond to the cause of the alarm condition	Beginning of potential injury ⁽¹⁾		
	Immediate ⁽²⁾	Prompt ⁽³⁾	Delayed ⁽⁴⁾
Death or irreparable injury	HIGH PRIORITY	HIGH PRIORITY	MEDIUM PRIORITY
Repairable injury	HIGH PRIORITY	MEDIUM PRIORITY	-
Bruising or discomfort	MEDIUM PRIORITY	-	-

- (1) Beginning of the potential injury refers to the occurrence of the injury and not to its manifestation.
 (2) There is potential for the event to be developed over a period of time not usually sufficient for manual corrective action.
 (3) There is potential for the event to be developed over a period of time usually sufficient for manual corrective action.
 (4) There is potential for the event to be developed in a non-specified period not greater than that provided in "prompt".

In this alarm system, there is no change in priority of the alarm condition and in the event of more than one alarm simultaneously:

- Alarm messages of high priority will be displayed alternately, following the priority described in
- Table 36.
- In the absence of high-priority alarms, the medium-priority alarms will be displayed alternately.

The alarm messages are displayed as soon as detected the alarm condition; so, there is no delay to display the messages.

Table 35: Alarm features

Alarm	Feature	High Priority	Medium Priority	Low Priority
Visual	Color	Red	Yellow	Cyan
	Intermittence frequency	1.42 hz	0.71 hz	Constant
Audible	Number of saved pulses	10 pulses	3 pulses	1 pulse
	Interval between saves	5.0 s	5.1 s	59,4 s

Alarm	Feature	High Priority	Medium Priority	Low Priority
	Sound pressure range	63.5 dBA	62 dBA	56,5 dBA
	Pulse frequency	688 hz	687 hz	686 Hz

Note

- It is recommended that the operator complies with the maximum distance of 1 meter to properly visualization and Identification of visual alarms; however, alarm signals are perceptible to 4 meter from the equipment.
- In order to identify the occurrence of an alarm, the operator should preferably be 1 meter from the front of the equipment at an angle of 30 ° with the horizontal axis in the center of the monitor's viewing plane.
- Sound pressure levels of auditory alarm signals that are lower than ambient levels may prevent operator recognition of alarm conditions.

Table 36: Alarm set

Item	Alarm		Setting	Standard Alarm ¹			Unit
				NEO	PED	ADU	
1	Maximum Pressure	High	5 to 80	30	30	40	cmH ₂ O
		Low	OFF; 1 to 79	OFF	OFF	OFF	
2	PEEP	High	OFF; 1 to 40	10	15	20	cmH ₂ O
		Low	OFF; 1 to 40	OFF	OFF	OFF	
3	Total Volume	High	OFF; 1 to 3000	50	500	1000	mL
		Low	OFF; 1 to 3000	OFF	OFF	OFF	
4	Minute volume	High	OFF; 1 to 99	5	10	20	L
		Low	OFF; 1 to 99	OFF	OFF	OFF	
5	Time for Apnea Alarm		OFF; 5 to 60	10	10	15	s
6	Respiratory Rate	High	OFF; 1 to 150	60	60	60	min ⁻¹
		Low	OFF; 1 to 150	OFF	OFF	OFF	
7	FiO ₂	High	OFF; 18 to 100	OFF	OFF	OFF	%
		Low	OFF; 18 to 100	OFF	OFF	OFF	
8	Automatic limit setting ³		OFF, 10, 20 and 30	OFF	OFF	OFF	%
9	Respiratory Rate ²	High	OFF; 1 to 240	180	120	120	bpm
		Low	OFF; 1 to 240	80	40	40	

Item	Alarm		Setting	Standard Alarm ¹			Unit
				NEO	PED	ADU	
10	SpO ₂ ²	Low	OFF; 30 to 100	85	85	85	%
11	EtCO ₂ ²	High	OFF; 1 to 80	45	45	45	mmHg
		Low	OFF; 1 to 80	OFF	OFF	OFF	
12	CO ₂ inspired ²	High	OFF; 1 to 80	4	4	4	mmHg

¹ Every time the equipment starts up or there is a change of patient type, or the battery power runs out without plugging the ventilator to mains, the alarms will assume the default values indicated for each type of patient.

² Alarms available only with the use of optional external sensors.

³ Only to be applied to the alarms related to basic ventilation parameters (Maximum Pressure, PEEP, Minute volume and Respiratory Rate).

WARNING

- **Default values of the alarms are only for initial reference. Reset the alarm limits as needed by the patient.**
- **There may be danger if different default alarm values are used for the same or similar equipment in the same area.**
- **Setting the alarm limit to its extreme value may make the alarm system inadequate. Adjust the limits as needed by the patient.**
- **Alarm settings will not change when power is lost for 30 seconds or less. In this case, the equipment will be powered by non-interchangeable internal battery.**
- **Oxygen monitoring is achieved accurately within 20 seconds of initialization.**

Alarms related to the equipment and ventilation:

- Low Battery
- Low Network Pressure
- Disconnection from the Breathing Circuit
- Obstruction of the Breathing Circuit
- Apnea
- No AC power

- Replace IRMA
- CO₂ out of scale
- Reading Error IRMA
- Calibrate IRMA
- SpO₂ Sensor
 - Caution SpO₂ Sensor (Sensor out of Finger)
 - Check SpO₂
 - Check Cable
 - Low Perfusion
 - Looking for pulse
 - Enabling SpO₂
 - SpO₂ demo

Alarms related to the external sensors:

- Capnography Sensor
 - Caution IRMA adapter
 - Restart IRMA

13.3.11 Concentration x Pressure in the breathing circuit curve

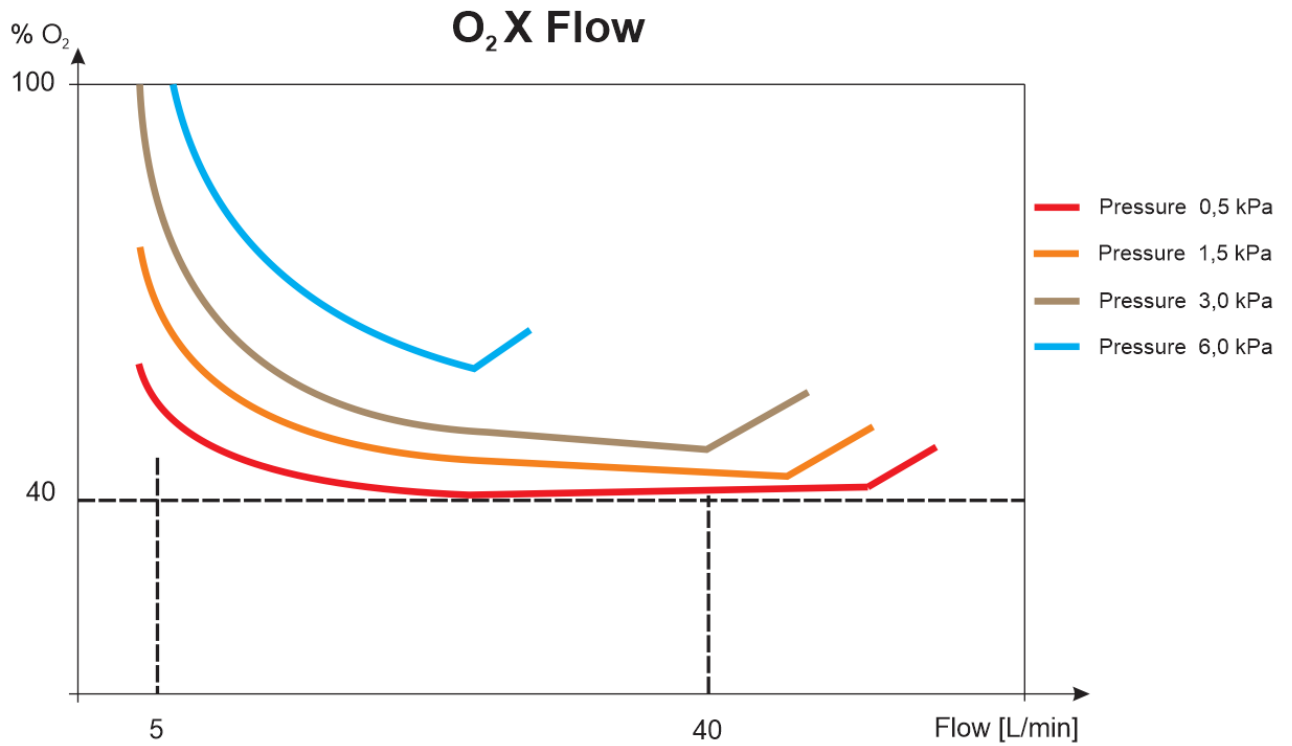

Figure 29: Concentration curve in function of pressure in the breathing circuit

13.3.12 Performance Specifications

Table 37: Performance specification

Item	Parameter	Specification	Tolerance	Unit
1	Maximum Flow in Pressure Support or in cycles of controlled pressure	150	± 10%	L.min ⁻¹
2	Control Principle	Cycled by Time, Constant Volume and Pressure Controlled	---	---
3	MTBF (Mean Time Between Failure)	5.000	---	hours (On) (POH)

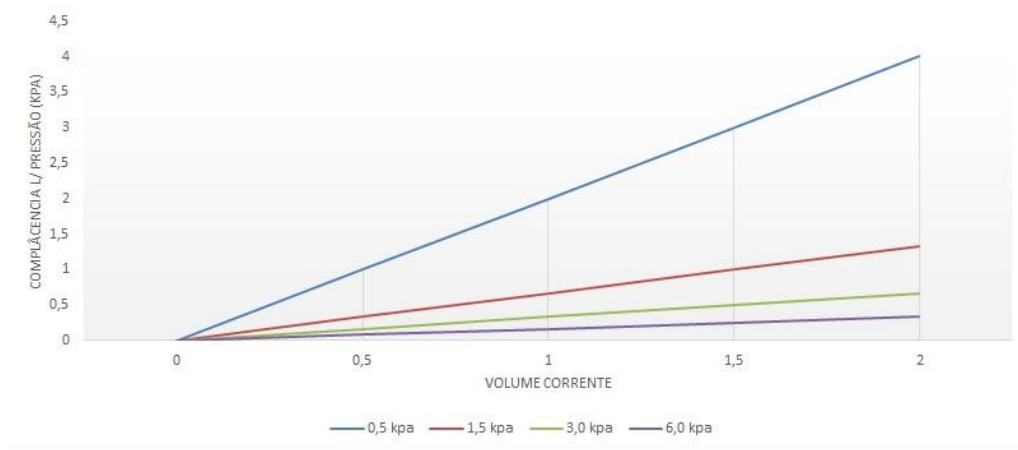

Figure 30: Influence of airway pressure on tidal volume⁽¹⁾

(1) To check the influence of airway pressure on minute volume, in the graph, the tidal volume applied by the monitored respiratory rate should be multiplied.

13.3.13 Specifications for Maintenance and Calibration

Caution

- Processing time is after stabilizing at specified temperature and pressure.
- Check sterilization efficiency through chemical or biological indicators.

Table 38: Specification for maintenance and calibration

Item	Description	Specification	Tolerance	Unit
1	Review and replace of diaphragm (3800248)	50 cycles of steam autoclave	---	cycles
		10.000 h or 2 years	± 500	Hours
2	Review and REPLACEMENT OF O ₂ CELL (3902020)	10,000 h or 2 years	± 500	Hours
3	Review and REPLACEMENT OF BATTERY (2702236)	10,000 h or 2 years	± 500	Hours
4	Exhalation valve (3200251)	50 cycles of steam autoclave	---	cycles
5	Breathing circuit - Adult (1703218), Pediatric (1702654)			

Item	Description	Specification	Tolerance	Unit
6	Universal connector with silicone thread 1,3 m			
7	Autoclavable flow sensor - Adult (3201100), Pediatric (3201099), Neonatal (3201098)			
8	Review	1	± 1 month	Year
9	Calibration	500h ⁽¹⁾	± 50	Hours
10	Air intake filter	500h ⁽¹⁾	± 50	Hours

(1) If environment in which it is used contains excessive particulate matter in suspension, replace air filter at shorter intervals

13.3.14 Mask for Non-Invasive Ventilation

Specification	
Adult/ Pediatric connection	22 mm
Neonatal connection	15 mm

13.3.15 Breathing Circuit

Specification	
Adult/ Pediatric connection	22 mm
Neonatal connection	15 mm
Resistance	≤ 0.3 mbar/L.s ⁻¹

13.3.16 HME Filter

Specification	
Adult/ Pediatric connection	22 mm
Bacterial Filtration Efficiency	99,999 %

13.3.17 Specifications for Resistance of the Expiratory Limb

Table 39: Expiratory Resistance in Function of Breathing Circuit and Accessories Aggregates

Breathing Circuit	Breathing circuit	Flow L x min ⁻¹	Expiratory Resistance (hPa or cmH2O) ¹			
			Circuit	Circuit + Flow Sensor	Circuit + Flow Sensor + HME Filter	Circuit + Flow Sensor + CO2 Sensor + HME Filter
Neonatal	Ped / Neo	5,0	0,8	1,3		
Pediatric	Ped / Neo	30,0	3,1	5,5	6,5	6,9
Adult	Adult	60,0	1,2	2,6	6.2	6,5

¹ The operator shall ensure that the inspiratory and expiratory resistance values are not exceeded when adding accessories or other components or subsets of the respiratory system

Table 40: Compliance specification of the breathing circuit

Breathing Circuit	Pressure (cmH2O)	Default Compliance ¹ (mL/cmH2O)	Maximum Compliance ² (mL/cmH2O)
Pediatric	60 ± 3	1	4
Adult	60 ± 3	2	5

¹ Default compliance will be used if the self-test is not performed, or the self-test fails.

² Maximum compliance for which accuracy is maintained.

13.3.18 Pneumatic diagram

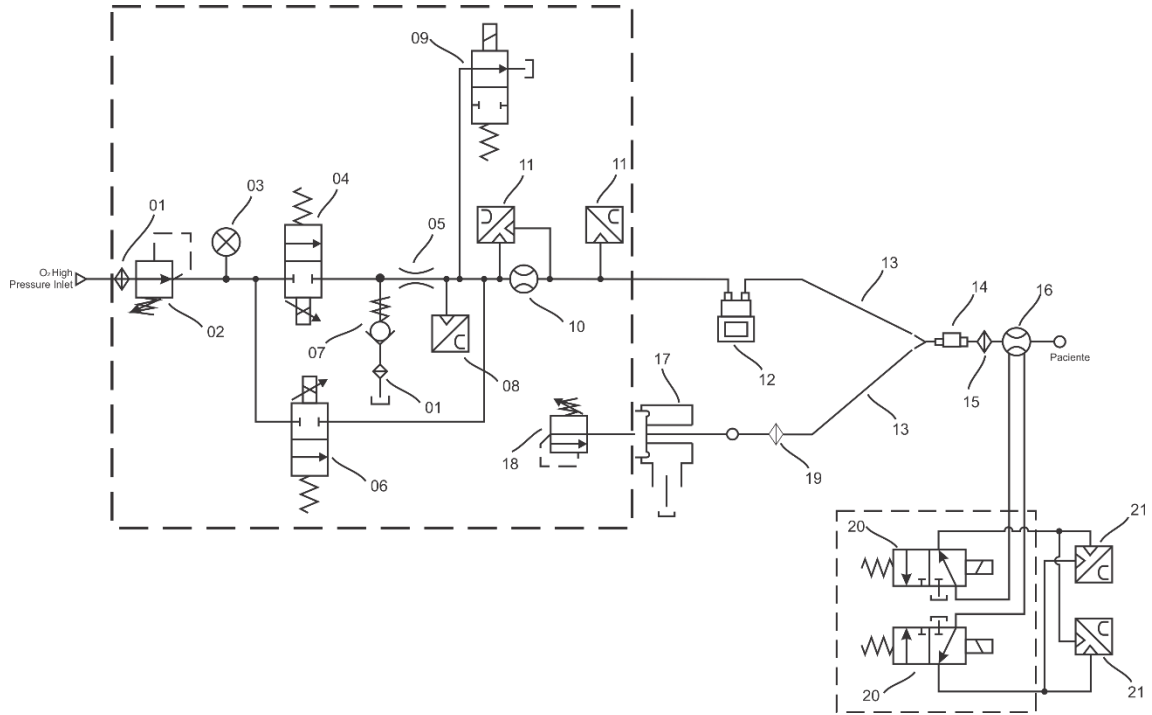

- | | |
|-------------------------------------|---|
| 1 Filter | 11 Pressure measuring point |
| 2 Pressure regulating valve 45 psi | 12 Humidifier (optional) |
| 3 Pressure sensor 150 psi | 13 Breathing circuit |
| 4 Proportional valve 30 LPM | 14 Capnograph (optional) |
| 5 Venturi system | 15 HEPA or HME filter |
| 6 Proportional valve 200 LPM | 16 Proximal flow sensor |
| 7 One-way valve (anti-asphyxiation) | 17 Exhalation valve |
| 8 O ₂ cell | 18 Linear actuator |
| 9 Overpressure valve On/Off | 19 HEPA filter |
| 10 Internal flow sensor | 20 Measuring point (proximal pressure differential) |
| | 21 Solenoid valve x-1 / 6 psi |

Figure 31: Pneumatic Scheme of the transport ventilator

13.3.19 Block Diagram of Control Electronics

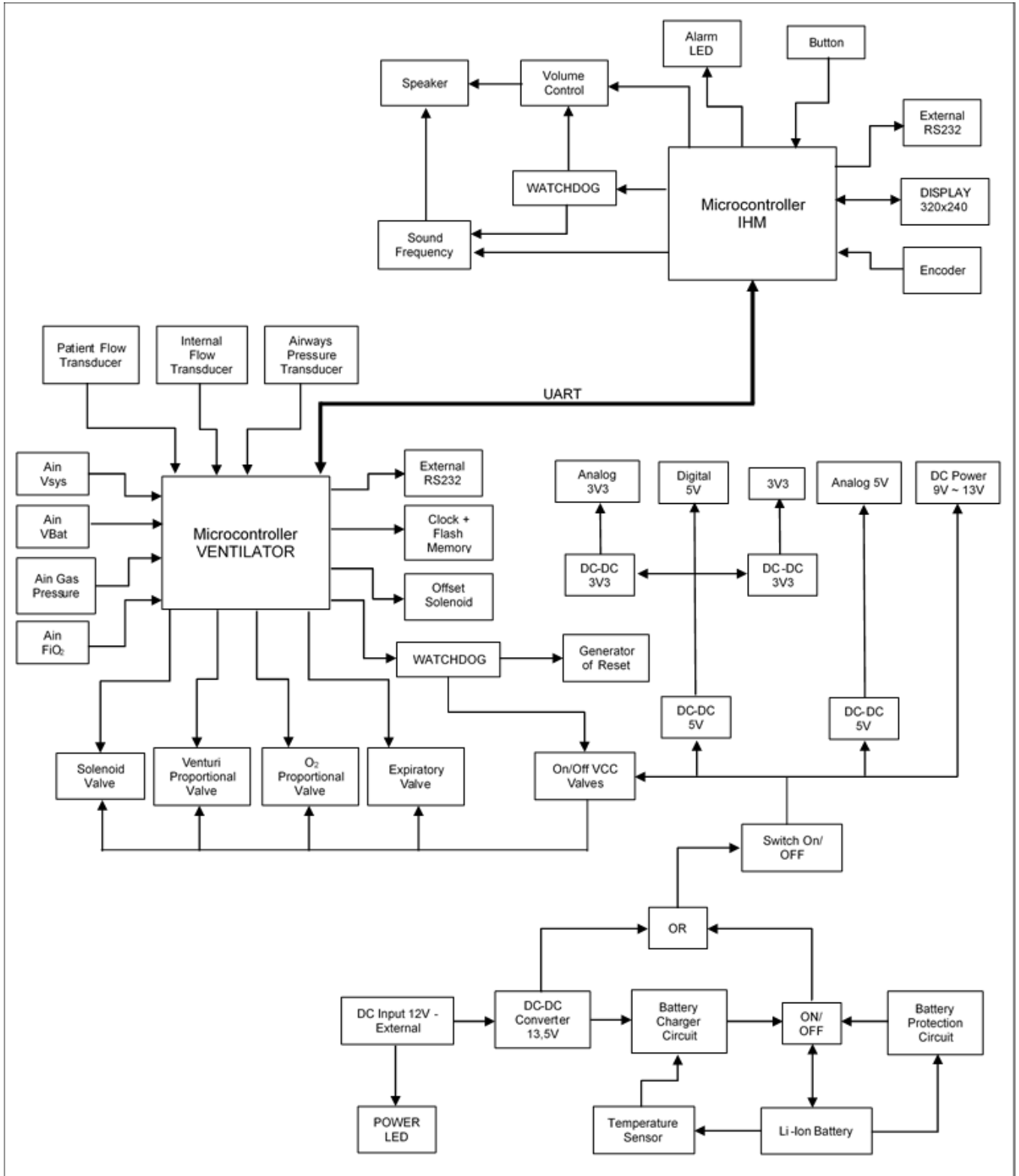

Figure 32: Block Diagram of Electronics

13.3.20 Electromagnetic Compatibility

Changes or modifications to this equipment not expressly approved by MAGNAMED can cause EMC problems with this equipment or another. Contact MAGNAMED to receive technical assistance. This equipment has been designed and tested to comply with applicable EMC standards as described below.

This equipment has been designed and tested to meet the following essential requirements: deliver ventilation to the patient connection port within alarm limits or generating an alarm condition; monitor oxygen concentration including high and low oxygen alarm; generate PEEP alarm above or below the alarm limit; generate obstruction alarm when airway pressure reaches the obstruction alarm limit; monitor expired volume and generate high priority alarm condition indicating high or low volume; generate alarm when there is a power failure and when the battery is low; generate high priority alarm when the oxygen network fails.

WARNING

- ***The use of cell phones or other radio frequency (RF) emitting devices near the system may cause unexpected or adverse outcomes. Monitor the operation if there are radio frequency emission sources in the vicinity.***
- ***The use of other electrical equipment in the system or around the system may cause interference. Before use in a patient, you must check if the equipment works normally in the defined configuration.***
- ***Use of this adjacent equipment or other equipment should be avoided as it may result in improper operation. If such use is required, this and other equipment should be observed to verify that they are operating normally.***
- ***Use of accessories, transducers, and cables other than those specified or supplied by Magnamed may result in high electromagnetic emissions or reduced electromagnetic immunity from this equipment and result in improper operation.***
- ***Portable RF communication equipment (including peripherals such as antenna cables and external antennas) should not be used within 30 cm of any part of Oxymag, including Magnamed specified cables. Otherwise, performance degradation of this equipment may occur.***
- ***If essential performance is requested or degraded due to electromagnetic disturbance, the ventilator may stop ventilating. In this case, the operator should provide manual ventilation facilities.***

A) Guidelines and manufacturer's statement – Electromagnetic emissions

The system is intended for use in the electromagnetic environment specified below. It is recommended that the customer or user of the system ensures that it is used in such an environment.

Table 41: Specification of electromagnetic environment of use

Emission Test	Compatibility	Directive for Electromagnetic Environment
RF Emissions IEC CISPR 11	Group 1	The system uses RF energy only for its internal functions. However, its RF emissions are very low and not likely to cause any interference in nearby electronic equipment.
RF Emissions IEC CISPR 11	Class B	The system may emit electromagnetic energy to perform its functions intended. Electronic equipment nearby may be affected.
Harmonics emission IEC 61000-3-2	Class A	
Emissions due to voltage fluctuation/ flicker IEC 61000-3-3	Complies	

B) Guidelines and manufacturer’s statement – Electromagnetic immunity

Oxymag is intended for use in the electromagnetic environment specified below. The buyer or user of **Oxymag** shall ensure that it is used in such an environment.

Table 42: Electromagnetic environment for use of the system

Immunity Test	IEC Test Level -60601-1-2	Compliance	Directive for electromagnetic environment
IEC 61000-4-2 – Electrostatic discharge (ESD)	± 8 kV by contact ± 15 kV by air	± 8 kV by contact ± 15 kV by air	Floors should be wood, concrete or ceramic. If floors are covered with synthetic material, relative humidity should be at least 30%
IEC 61000-4-4 – Electrical fast transient / Burst	± 2 kV at the power input interface c.a. ± 2 kV at the power input interface c.c. ± 1 kV at signal input / output parts	± 2 kV at the power input interface c.a. ± 2 kV at the power input interface c.c. ± 1 kV at signal input / output parts	Quality of power supply should be that of a typical commercial or hospital environment.
IEC 61000-4-5 - Surge	± 1 kV line(s) to line(s) ±2 kV line(s) to earth	± 1 kV line(s) to line(s) ±2 kV line(s) to earth	Quality of power supply should be that of a typical commercial or hospital environment.
IEC 61000-4-11 – Voltage dips	0% UT; 0.5 cycle at 0 °, 45 °, 90 °, 135 °, 180 °, 225 °, 270 ° and 315 ° 0% UT; 1 cycle (single phase: at 0 °) 70% UT; 25/30 cycles (single phase: at 0 °)	0% UT; 0.5 cycle at 0 °, 45 °, 90 °, 135 °, 180 °, 225 °, 270 ° and 315 ° 0% UT; 1 cycle (single phase: at 0 °) 70% UT; 25/30 cycles (single phase: at 0 °)	Quality of power supply should be that of a typical commercial or hospital environment.
IEC 61000-4-11 – Voltage interruption	0 % UT; 250/300 cycles	0 % UT; 250/300 cycles	Quality of power supply should be that of a typical commercial or hospital environment.
Magnetic field of power frequency (50/60 Hz) IEC 61000-4-8	30 A/m	30 A/m	Magnetic fields in the supply frequency should be at levels characteristic of a typical location in a typical commercial or hospital environment

Note: UT is the a.c. supply voltage before application of the test level.

Table 43: Radiated Immunity

Oxymag is intended for use in the electromagnetic environment specified below. The buyer or user of Oxymag shall ensure that it is used in such an environment.

Immunity Test	Test Level IEC 60601	Compliance	Electromagnetic environment – Guidelines
---	---	---	It is not advisable to use mobile or portable RF communication equipment at shorter distances from any part of Oxymag, including cables, than the recommended separation distance, calculated by the equation applicable to the frequency of the transmitter. Recommended separation distance
Conducted disorders induced by RF fields ^(a) IEC 61000-4-6	3 Vrms 0,15 MHz to 80 MHz outside the ISM bands ^(a)	3 V	$d = 1,2\sqrt{P}$
---	10 Vrms 0,15 MHz to 80 MHz outside the ISM bands ^(a)	10 V	$d = 1,2\sqrt{P}$
EM fields of Radiated RF IEC 61000-4-3	10 V/m 80 MHz to 2,7 GHz	10 V/m	$d = 1,2\sqrt{P}$ 80 MHz to 800 MHz
---	---	---	$d = 2,3\sqrt{P}$ 800 MHz to 2,7 GHz Where P is the declared maximum level of transmitter output power in watts (W) according to the transmitter manufacturer, and d is the recommended separation distance in meters (m). ^b The field strength from RF transmitters, determined by an electromagnetic field survey, ^c should be less than the level of compliance for each frequency range. ^d Interference may occur in the vicinity of the equipment marked with the following symbol: 

NOTE 1 At 80 MHz and 800 MHz, the higher frequency range applies.

NOTE 2 These guidelines may not apply in all situations. Electromagnetic propagation is affected by absorption and reflection from structures, objects, and people.

a The industrial, scientific and medical (ISM) bands between 0.15 MHz and 80 MHz are 6.765 MHz to 6.795 MHz; 13,553 MHz to 13,567 MHz; 26.957 MHz to 27.283 MHz; and 40.66 MHz to 40.70 MHz. Amateur radio bands between 0.15 MHz and 80 MHz are 1.8 MHz to 2.0 MHz, 3.5 MHz to 4.0 MHz, 5.3 MHz to 5 MHz, 4 MHz, 7 MHz to 7.3 MHz, 10.1 MHz to 10.15 MHz, 14 MHz to 14.2 MHz, 18.07 MHz to 18.17 MHz, 21.0 MHz to 21.4 MHz, 24.89 MHz to 24.99 MHz, 28.0 MHz to 29.7 MHz and 50.0 MHz to 54.0 MHz.

b Compliance levels in the ISM frequency bands between 0.15 MHz and 80 MHz and in the 80 MHz to 2.7 GHz frequency range are set to reduce the possibility of mobile / portable RF communication equipment causing interference if inadvertently brought into patient areas. Therefore, an additional factor of 10/3 has been incorporated into the formulas used in calculating the recommended separation distance for transmitters in these frequency ranges.

c Field strength from fixed transmitters such as telephone base stations (mobile or cordless) and mobile ground radios, amateur radio, AM and FM radio broadcasts and TV broadcasts cannot be predicted theoretically with precision. To assess the electromagnetic environment generated by fixed RF transmitters, an electromagnetic field survey should be considered. If the measured field strength at the location where Oxymag will be used exceeds the applicable RF CONFORMITY LEVEL set

above, Oxymag should be observed to verify that it is operating normally. If abnormal performance is detected, additional measures may be necessary, such as reorienting or relocating Oxymag.

d Above the frequency range 0.15 MHz to 80 MHz, the field strength should be less than 3 V / m.

C) Recommended separation distance between portable and/or mobile RF communications equipment and the system

Oxymag is intended for use in the electromagnetic environment in which radiated RF disturbances are controlled. The customer or user of Oxymag can help prevent electromagnetic interference by maintaining a minimum distance between the portable and mobile RF communications equipment (transmitters) and the Oxymag as recommended below, according to the maximum output power of the communication equipment.

Table 44: Separation distance according to the transmitter frequency (m)

Maximum output power of the transmitter (W)	150 kHz - 80 MHz Out of the ISM bands	150 kHz - 80 MHz Within the ISM bands	80 MHz - 800 MHz	800 MHz – 2.5 GHz
	d = 1,2VP	d = 1,2VP	d = 1,2VP	d = 2,3VP
0,01	0,12	0,12	0,12	0,23
0,1	0,38	0,38	0,38	0,73
1	1,2	1,2	1,2	2,3
10	3,8	3,8	3,8	7,3
100	12	12	12	23

For transmitters with a stated maximum output power level not listed above, the recommended separation distance d in meters (m) can be determined using the transmitter frequency equation. Where P is the declared maximum transmitter output power in watts (W) according to the transmitter manufacturer.

NOTE 1 At 80 MHz and 800 MHz, the separation distance for the higher frequency range applies.

NOTE 2 ISM bands (industrial, scientific, and medical) between 0.15 MHz and 80 MHz are 6.765 MHz to 6.795 MHz; 13,553 MHz to 13,567 MHz; 26.957 MHz to 27.283 MHz; and 40.66 MHz to 40.70 MHz. Amateur radio bands between 0.15 MHz and 80 MHz are 1.8 MHz to 2.0 MHz, 3.5 MHz to 4.0 MHz, 5.3 MHz to 5 MHz, 4 MHz, 7 MHz to 7.3 MHz, 10.1 MHz to 10.15 MHz, 14 MHz to 14.2 MHz, 18.07 MHz to 18.17 MHz, 21.0 MHz to 21.4 MHz, 24.89 MHz to 24.99 MHz, 28.0 MHz to 29.7 MHz and 50.0 MHz to 54.0 MHz.

NOTE 3 An additional factor of 10/3 has been incorporated into the formulas used to calculate the recommended separation distance for transmitters in the ISM frequency bands between 0.15 MHz and 80 MHz and in the 80 MHz to 2.7 GHz frequency range, with the goal of reducing the possibility of mobile / portable RF communication equipment causing interference if inadvertently brought into patient areas.

NOTE 4 These guidelines may not apply in all situations. Electromagnetic propagation is affected by absorption and reflection from structures, objects, and people.

Fields in the vicinity of RF wireless communication equipment

The Oxymag cabinet interface has been tested as specified in the table below using the test methods specified in IEC 61000-4-3

Band [MHz]	Freq. test [MHz]	Modulation	Trial level [V/m]
380 to 390	385	Pulse, 18 Hz	27
430 to 470	450	FM, 1 kHz, Deviation from ± 5kHz	28
704 to 787	710 745 780	Pulse, 217 Hz	9
800 to 960	810 870 930	Pulse, 18 Hz	28
1.700 to 1.990	1.720 1.845 1.970	Pulse, 217 Hz	28
2.400 to 2.570	2.450	Pulse, 217 Hz	28
5.100 to 5.800	5.240 5.500 5.785	Pulse, 217 Hz	9

D) Electrical Safety

The following are the precautions that should be observed when combining these items (non-medical equipment) with the system.









WARNING













- *Items that do not meet the requirements of standard IEC 60601-1 cannot be placed within 1.5 from the patient.*
- *All items (electromedical or non-medical equipment) connected to the system with input/output signal cable must receive power from an AC source using separate transformer (according to standard IEC 60989) or provide additional earth protective conductor.*
- *Multiple portable sockets with switch used on AC power supplies must comply with IEC 60601-1-1 and cannot be installed on the floor. Do not use more than one power strip with portable switch.*
- *Do not connect directly the non-medical electrical equipment to an AC wall outlet. Use AC power supply with its own transformer. Otherwise, the leakage current will increase above the levels accepted by IEC 60601- under normal conditions and single-failure conditions. This may cause dangerous electrical shock to the patient or operator.*
- *After connecting any equipment into these outlets, the system should undergo a complete test for leakage current (according to standard IEC 60601-1).*
- *The operator of the electromedical system must not touch the non-medical electrical equipment and the patient at the same time. This may cause dangerous electrical shock to the patient or operator.*









13.4 O₂ galvanic cell specification











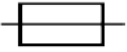



General specification	
Intended use	Measure the O ₂ concentration delivered from the equipment to the patient
Measuring range	0 to 100%
Output sign	9 – 13 mV
Response time 90%	13 s
Accuracy	± 2%
Linearity	± 2%
Recommended flow rate	0.1 – 10 lpm
Data sampling rate	7 Hz
Method for calculating the gas level reading	Simple moving average (MMS) of 64 positions acquired every 140ms
Respiratory rate	The Respiratory Rate is shown every 3 breaths and the average value is updated with each breath.
Effects of gas and vapor interference	
Gases or Steam	Gas Level
Response to 80% NO	< 5%
Response to 7,5% Halothane	< 5%
Response to 7,5% Isoflurane	< 5%
Response to 7,5% Enflurane	< 5%
Response to 9% Sevoflurane	< 5%
Response to 20% Desflurane	< 5%
Response to 10% CO ₂	< 5%



14 Symbols

SYMBOLS / UNIFIED TEXTS	PORTUGUÊS	ESPAÑOL	ENGLISH
	PACIENTE	PACIENTE	PATIENT
	CORRENTE CONTÍNUA	CORRIENTE CONTINUA	CONTINUOUS TIDAL
	CORRENTE ALTERNADA (REDE)	CORRIENTE ALTERNA (RED)	ALTERNATING CURRENT (POWER)
	ENERGIA ELÉTRICA	ENERGÍA ELÉCTRICA	ELECTRIC ENERGY
	RECOLHIMENTO DE EQUIPAMENTO ELÉTRICO/ELETRÔNICO FEITO DE FORMA SEPARADA	RECOGIMIENTO DE EQUIPO ELÉCTRICO ELECTRÓNICO HECHO POR SEPARADO	WASTE – ELECTRICAL AND ELECTRIC EQUIPMENT SHALL BE COLLECTED AND RECYCLED IN ACCORDANCE WITH DIRECTIVE 2002/96/EC
	ENTRADA DC	ENTRADA DC	DC INPUT
	CONEXÃO DE FORÇA	CONEXÃO DE FORÇA	POWER PLUG
	LIGA	ON	ON
	DESLIGA	OFF	OFF
INSP / EXP HOLD	PAUSA INSPIRATÓRIA/ EXPIRATÓRIA	PAUSA INSPIRATORIA/ ESPIRATORIA	INSPIRATORY/ EXPIRATORY HOLD
MANUAL	DISPARO MANUAL	GATILLO MANUAL	MANUAL TRIGGER
O₂ 100%	100% OXIGÊNIO	100% OXIGENO	OXYGEN 100%
 O O 	SERIAL	SERIAL	SERIAL

SYMBOLS / UNIFIED TEXTS	PORTUGUÊS	ESPAÑOL	ENGLISH
	IDENTIFICAR OU ACONSELHAR LIMPEZA OU TROCA DE FILTRO	IDENTIFICAR O ASESORAR LA LIMPIEZA O EL CAMBIO DEL FILTRO	TO IDENTIFY OR ADVISE CLEANING OR CHANGING A FILTER
	TRAVAR TECLADO	TRABAR TECLADO	KEYBOARD LOCK
	MANUTENÇÃO PERIÓDICA	MANTENIMIENTO PERIÓDICO	PERIODIC MAINTENANCE
	CONGELA	CONGELA	FREEZE
	PÁGINA	PAGINA	PAGE
	ALARME AUDIO PAUSADO	ALARMA AUDIO PAUSADO	AUDIO ALARM PAUSED
	ALARME	ALARMA	ALARM
IP34	PROTEGIDO CONTRA RESPINGOS DE ÁGUA E ENTRADA DE PARTES SÓLIDAS MAIOR OU IGUAL A 2,5MM	PROTEGIDO CONTRA SALPICADURAS DE AGUA Y ENTRADA DE PARTES SÓLIDAS MAYOR O IGUAL A 2,5MM	PROTECTED AGAINST WATER SPRAYS AND THE INGRESS OF SOLIID PARTS OF 2,5MM OR BIGGER
	PARTE APLICADA TIPO BF	PARTE APLICADA TIPO BF	TYPE BF OF APPLIED PART
	EQUIPAMENTO CLASSE II	EQUIPO CLASE II	CLASS II EQUIPMENT
	DATA DE FABRICAÇÃO	FECHA DE FABRICACIÓN	MANUFACTURE DATE
	FABRICANTE	FABRICANTE	MANUFACTURE
	REPRESENTANTE EUROPEU	REPRESENTANTE EUROPEO	EUROPEAN REPRESENTATIVE
	ATENÇÃO! CONSULTAR DOCUMENTOS ACOMPANHANTES	ATENCIÓN! CONSULTAR DOCUMENTOS QUE ACOMPANAN	ATTENTION! SEE ACCOMPANYING DOCUMENTS

SYMBOLS / UNIFIED TEXTS	PORTUGUÊS	ESPAÑOL	ENGLISH
	INSTRUÇÃO DE USO	MANUAL DE INSTRUCCIONES	OPERATING INSTRUCTIONS
	FRÁGIL	FRÁGIL	FRAGILE
	FACE SUPERIOR NESTA DIREÇÃO	LADO SUPERIOR EN ESTA DIRECCIÓN	THIS SIDE UP
	PROTEGER CONTRA UMIDADE	PROTEGER CONTRA LA HUMEDAD	FEARS HUMIDITY
	QUANTIDADE SEGURA DE EMPILHAMENTO	SOSTENIMIENTOS DE LA CANTIDAD DE AMONTANAR	SAFE STACKING QUANTITY
	LIMITES DE TEMPERATURA	LIMITES DE TEMPERATURA	TEMPERATURE LIMITS
	MANTENHA PROTEGIDO DO SOL	MANTENER PROTEGIDO DEL SOL	KEEP AWAY FROM HEAT
EtCO ₂ / SpO ₂	CONEXÃO DE ENTRADA DO SENSOR DE CAPNOGRAFIA / OXIMETRIA	CONEXIÓN DE ENTRADA DEL SENSOR DE CAPNOGRAFÍA / OXIMETRÍA	CAPNOGRAPHY / OXIMETRY SENSOR INPUT CONNECTION
O ₂ INLET	ENTRADA DE O ₂	ENTRADA DE O ₂	O ₂ INLET
O ₂	OXIGÊNIO	OXIGENO	OXYGEN
	AJUSTE DE ALARME OFF	AJUSTE DE ALARMA OFF	ALARM SETTING OFF
	STAND BY	STAND BY	STAND BY
INSP	INSPIRATÓRIA	INSPIRATORIA	INSPIRATORY
EXP	EXPIRATÓRIA	ESPIRATORIO	EXPIRATORY

SYMBOLS / UNIFIED TEXTS	PORTUGUÊS	ESPAÑOL	ENGLISH
	FUSÍVEL	FUSIBLE	FUSE
	CONFORMIDADE CE: INDICA QUE O SISTEMA ESTÁ EM CONFORMIDADE COM O REGULAMENTO (EU) 2017/745	CONFORMIDAD CE: INDICA QUE EL SISTEMA ESTÁ EN CONFORMIDAD CON EL REGLAMENTO (UE) 2017/745	CONFORMITY CE: INDICATES THAT THE SYSTEM IS IN ACCORDANCE WITH REGULATION (EU) 2017/745
	INMETRO	INMETRO	INMETRO
	A LEGISLAÇÃO FEDERAL DOS EUA RESTRINGE A VENDA DESTES DISPOSITIVO OU POR ORDEM DE UM MÉDICO	LA LEGISLACIÓN FEDERAL DE LOS ESTADOS UNIDOS RESTRINGE LA VENTA DE ESTE DISPOSITIVO O POR ORDEN DE UN MÉDICO	US FEDERAL LAW RESTRICTS THIS DEVICE TO SALE BY OR ON THE ORDER OF A PHYSICIAN
	DATA DE VALIDADE	FECHA DE VALIDEZ	USE BY DATE
	NÃO ESTÉRIL	NO ESTERIL	NON-STERILE
	NÃO USAR SE A EMBALAGEM ESTIVER DANIFICADA	NO UTILIZAR SI EL PAQUETE ESTÁ DAÑADO	DO NOT USE IF PACKAGE IS DAMAGED
	O MANUAL DE INSTRUÇÕES DEVE SER LIDO	EL MANUAL DE INSTRUCCIONES DEBE SER LIDO	THE INSTRUCTION MANUAL MUST BE READ
	NÚMERO DO CATÁLOGO DO FABRICANTE	NÚMERO DE CATÁLOGO DEL FABRICANTE	MANUFACTURER'S CATALOGUE NUMBER
	NÚMERO DE SÉRIE DO FABRICANTE	NÚMERO DE SERIE DEL FABRICANTE	MANUFACTURER'S SERIAL NUMBER
	CÓDIGO DE LOTE DO FABRICANTE	CÓDIGO DE LOTE DEL FABRICANTE	MANUFACTURER'S MATCH OR LOT CODE
	USO ÚNICO	USO ÚNICO	SINGLE USE
	SAÍDA DE GÁS	SALIDA DE GAS	GAS OUTPUT
	ENTRADA DE GÁS MOTRIZ	ENTRADA DE GAS CONDUCTOR	DRIVING GAS INPUT

SYMBOLS / UNIFIED TEXTS	PORTUGUÊS	ESPAÑOL	ENGLISH
	EXAUSTÃO	ESCAPE	EXHAUSTION
	<p>AFERIÇÃO DA PRESSÃO Essa aferição é uma técnica de leitura de fluxo e volume. A leitura de pressão nas vias aéreas é realizada internamente.</p>	<p>MEDICIÓN DE PRESIÓN Esta medición es una técnica de lectura de flujo y volumen. La lectura de la presión de la vía aérea se realiza internamente.</p>	<p>PRESSURE GAUGE This measurement is a flow and volume reading technique. Airway pressure reading is performed internally.</p>
	<p>LIMITAÇÃO DE PRESSÃO ATMOSFÉRICA Indica a faixa de pressão atmosférica à qual o equipamento pode ser exposto com segurança.</p>	<p>LIMITACIÓN DE PRESIÓN ATMOSFÉRICA Indica el rango de presión atmosférica a la que el dispositivo médico puede exponerse de manera segura.</p>	<p>HUMIDITY LIMITATION Indicates the range of humidity to which the medical device can be safely exposed.</p>
	<p>LIMITAÇÃO DA UMIDADE Indica a faixa de umidade à qual o equipamento pode ser exposto com segurança.</p>	<p>LIMITACIÓN DE HUMEDAD Indica el rango de humedad a la que el dispositivo médico puede exponerse de manera segura.</p>	<p>ATMOSPHERIC PRESSURE LIMITATION Indicates the range of atmospheric pressure to which the medical device can be safely exposed.</p>

15 Terms and Abbreviations

Table 45: List of terms and abbreviations with their descriptions

Terms and Abbreviation	Description	Terms and Abbreviation	Description
ADU	Adult	I:E	Ratio T.Insp by TExp
Backup	Apnea Mode Setting	BMI	Body Mass Index
C.Dyn	Dynamic Compliance	INF	Infant
CO _{2i} ↑	Alarm setting High CO ₂ inspired	Man Trig	Manual Trigger
Compliance	Circuit Compliance	MV	Minute Volume
Cons O ₂	O ₂ Consumption	NEO	Neonatal
C.Stat	Static Compliance	NIV	Non-Invasive Ventilation
CPAP	Continuous Positive Airway Pressure Ventilation	O ₂ 100%	Flash indication of O ₂
Cycl. PS	Cycling Percentage	Pause	Inspiratory Pause
DualPAP	Dual-level CPAP Ventilation	PCV	Pressure Controlled Ventilation
FiO ₂	O ₂ Inspired Fraction	PED	Pediatric
Freq	Total Respiratory Rate	PEEPi	Intrinsic PEEP
F.Base	Baseline Flow	P. Lower	Lower Pressure of DualPAP mode
Fspn	Spontaneous Frequency	P. Insp	Setting of Inspiratory Pressure
Fl Tig F.Trigger	Trigger (Sensitivity) to Flow	PLV	Pressure Limited Ventilation
P Mean	Mean Pressure	P.Max	Maximum Pressure in the Airways
P.Plat	Plateau Pressure	T. Lower	Lower Time of DualPAP mode
Prede	Network Pressure	T. High	Upper Time of DualPAP mode
Pr Trig P.Trigger	Trigger (Sensitivity) to Pressure	Exp Valve	Expiration Valve
Prox	Next Page	Leakage	Circuit Leakage
P-SIMV	Controlled Pressure Synchronized Intermittent Mandatory Ventilation	VCV	Volume Controlled Ventilation

Terms and Abbreviation	Description
PSV	Continuous Pressure Ventilation with Pressure Support
P. High	High pressure of DualPAP mode
P.Low	Low pressure
Res	Airway resistance
Resistance	Circuit Resistance
Rise Time	Rise Time
SpO ₂	Oxygen Saturation in the Blood
T.Exp	Expiratory Time
T.Insp	Inspiratory Time

Terms and Abbreviation	Description
VMspn	Spontaneous Minute Volume
V-SIMV	Synchronized Intermittent Mandatory Ventilation with Controlled Volume cycle
Vspn	Spontaneous Volume
Vt	Adjusted Tidal Volume
Vti	Inspired Tidal Volume
Vte	Exhaled Tidal Volume
Δ PS	Value to be added to PEEP pressure to obtain Pressure Support
\dot{V}	Tidal flow
HR	Heart Rate

16 Statement of Biocompatibility

We declare under our sole responsibility that all materials used in applied parts (as defined by the NBR IEC 60601-1 standard) in OxyMag have been widely used in the medical field over time, without effects related to toxicity or effects on tissue, thus ensuring its biocompatibility.

And according to ISO-10993-1 Biological evaluation of medical devices — Part 1: Evaluation and testing – clause 4.2.1 - the ventilator, its parts and accessories are classified as a device without direct or indirect contact with the patient's body , therefore the ventilator, its parts and accessories are not included in the scope of this standard.

WARNING

- ***Common accessories purchased from third parties MUST comply local legal government requirements.***
-

17 Warranty

The manufactured Products and marketed by MAGNAMED TECNOLOGIA MÉDICA S/A are warranted against material and manufacture defects as provided below.

The warranty period for the equipment is 12 months. For batteries and accessories, the periods of 3 months, provided that retained their original features; this period is from the date of purchase by the first purchaser of the product, as stated on the Sales Invoice of MAGNAMED TECNOLOGIA MÉDICA S/A.

The responsibility for warranty is limited to exchange, repair and hand labor for the defective parts or not meeting the specifications in the Product Operation Manual.

The warranty is limited to the product used under normal conditions and for the purposes for which it is intended, and which preventive maintenance and part replacements and repairs are carried out in accordance with the instructions in the Product Operation Manual, by personnel authorized by the manufacturer.

The warranty does not cover defects caused by misuse or mis installation, accident, improper sterilization, service, installation, operation or modification carried out by personnel not authorized by the manufacturer.

The disruption or absence of seals or warranty seals by unauthorized personnel results in the loss of product warranty.

Parts subject to wear or deterioration due to normal use, rough use, misuse, or accidents are not covered by warranty. Any costs and risks with transportation of the product are not covered by this warranty. There is no express or implied warranty than those set out above.

18 Technical Assistance

For maintenance, please contact our technical assistance who will indicate the service nearest you or visit our website.

19 Training

To request training, please contact Magnamed product expert team who will indicate the authorized Representative nearest you.

Website: www.magnamed.com.br
Email: magnamed@magnamed.com.br

MAGNAMED

Manufacturer / Technical Assistance / Customer Service



Magnamed Tecnologia Médica S/A
Rua Santa Mônica, 801 - 831 – Bairro Capuava
CEP: 06715-865 – Cotia – SP – Brasil
Phone/Fax: +55 (11) 4615-8500
E-mail: magnamed@magnamed.com.br
Website: www.magnamed.com.br
CNPJ: 01.298.443/0002-54
State Registration: 149.579.528.111

Technical Responsible: Toru Miyagi Kinjo
Registration at CREA-SP: 5061555031